

In due order
November 14, 1946
J. Scacchetti

APPLICATION NO AP 4840

Dated October 22, 1946.
Received October 25, 1946.
Granted April 18, 1947.

MEMBERSHIP NO 4840



THE AMERICAN INSTITUTE OF ARCHITECTS

APPLICATION FOR MEMBERSHIP

RECORD OF THE SECRETARY OF THE INSTITUTE

- A Name of applicant..... John Scacchetti..... Chapter New Jersey.....
- B Address of applicant..... 1914 Palisade Ave., Union City, New Jersey.....
- C Applicant proposed by.... Fritz Steffens..... and.... Laurence Scacchetti.....
- D Application received with check for \$10.00..... on..... October 25, 1946.
- E Application ~~received~~ held for correction (Wrote re: address in N.Y. for membership in N.Y. Chap.)..... October 29, 1946.
- F Application in due order on..... November 14, 1946.
- Record of registration, Form S39, Sent (N.J.) Oct. 29, 1946 Received. November 4, 1946
(N.J.) Oct. 29, 1946 October 31, 1946
- G Notices sent to chapter executive committee:
 - (a) Form S11, reasonable time ending on..... December 14, 1946 on November 14 1946.
 - (b) Form S12, 30 day extension ending on..... 19...., on 19 ..
- H Acknowledgments to applicant, proposers, and chapter on..... October 29, 1946.
- I Certified resolution of chapter executive committee recommending admission ~~received~~ received on..... March 7, 19 47
- J No report from chapter executive committee on..... 19 ..
- K Application sent to The Board of Examiners on..... April 10, 1947.
- L The Board of Examiners reported on application on..... April 10, 1947.
- M Applicant was admitted on..... April 18, 19 47
- N Notice and certificate to applicant and notice of assignment to chapter and letter to proposers on..... April 18, 19 47
- O Notice of denial of application to chapter and applicant and \$..... returned to applicant on..... 19 ..

CERTIFICATION OF ELECTION AND ASSIGNMENT

I, Secretary of The American Institute of Architects, hereby certify that, under authority vested in me by The Board of Directors, I have this day duly elected

John Scacchetti

to membership in The Institute, and hereby declare him to be a corporate member of The Institute and assign him to membership in the New Jersey Chapter.

Date April 18, 19 47.

Alexander C. Robinson
Secretary

THE AMERICAN INSTITUTE OF ARCHITECTS ARCHIVES For information or study purposes only. Not to be recycled, quoted, or published without written permission from the AIA Archives, 1735 New York Ave. NW, Washington, DC 20006

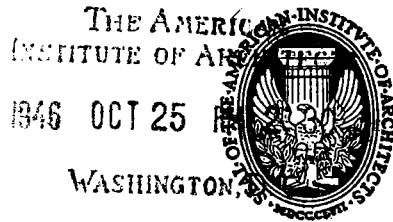

INSTRUCTIONS

Type in all information carefully and sign with ink.

Mail this original and check for \$10.00 to The Secretary, The American Institute of Architects, 1741 New York Avenue, N. W., Washington 6, D. C.

File the duplicate, on yellow paper, with the secretary of the local Chapter of The Institute.

The American Institute of Architects

APPLICATION FOR CORPORATE MEMBERSHIP

I, the undersigned, do hereby apply for corporate membership in The American Institute of Architects.

1. My full name is John Scacchetti
2. I am a natural citizen of the United States of America
2. State whether a natural or a naturalized citizen.
3. My legal residence is in the City of Union City,
 County of Hudson State of New Jersey.
4. My address in The Institute records will be
4. State whether residence or office address.
 Number 1914 Street Palisade Avenue
 City Union City State New Jersey
5. I am engaged in the profession of architecture as practising architect.
6. I desire to be a member of the New York *New Jersey* Chapter.
5. State whether as a practicing architect, a teacher, a public official, etc.
7. I declare that I will comply with the By-laws and the Principles of Professional Practice of The American Institute of Architects, and the Rules and Regulations supplementary thereto, and that I understand the duties, responsibilities, and obligations of a member of The Institute.
8. I have filed the duplicate of this application with the secretary of the Chapter above named. I am not indebted to The Institute or to any of its component organizations.
9. I enclose my check for \$10.00, for admission fee and the first year's annual dues. It is my understanding that if I am not admitted to membership \$5.00 will be returned to me, and \$5.00 retained by The Institute as an examination fee.

Date Oct. 22 1946

John Scacchetti
 Applicant sign full name in ink

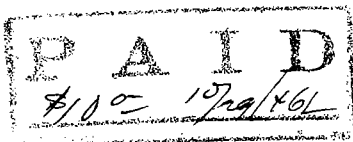

STATISTICS

10. Date of birth Dec. 25th, 1900 Place of birth New York City

11.(a) I am registered or licensed to practice architecture in the following-named states:

- a. New Jersey - License No. C-1684
- B. New York State - License No. 4748

(b) I passed the State Board Examination in the following-named states:

New York State

(c) I hold Certificate No. 571 of the National Council of Architectural Registration Boards, for having passed their Standard Examination.

EDUCATION

12.(a) I attended high schools, private schools, colleges, universities, as follows:

<i>Names of School, College University</i>	<i>Location</i>	<i>No. of Years</i>	<i>Year of Graduation</i>	<i>Degree</i>
West Hoboken High	Union City, N.J.	1		
New York Prep.	New York City	2	1935	16½ Credits
Mechanics Institute	New York City	4	1919	
Columbia University	New York City		1922-23	
			1927-28	
College of City of N.Y.	" " "		1921-23	

(b) I have held the following-named scholarships and have traveled in the following-named countries:

PROFESSIONAL TRAINING

13. I list below, in chronological order, the periods of my training as draftsman, the names and addresses of my principal employers, and my classification as draftsman while employed by each:

- 1916-1919 - Schwatz & Gross - 347 - 5th Ave., New York - Draftsman
- 1919-1921 - William Laurence Bottomley - 545 - 5th Ave., New York
Chief Draftsman
- 1927-1939 - William Laurence Bottomley - 545 - 5th Ave., New York
Job Captain
- 1921-1926 - Sugarman & Berger (Both deceased)
- 1941-1945 - Kelly & Gruzen - 220 Broadway, New York - Office manager

THE AMERICAN INSTITUTE OF ARCHITECTS ARCHIVES For information or study purposes only. Not to be recycled, quoted, or published without written permission from the AIA Archives, 1735 New York Ave. NW, Washington, DC 20006

PROFESSIONAL PRACTICE

14. I list below, in chronological order, the periods during which and the states in which I have practiced architecture as an individual or as a member of a firm or corporation or as a public official or have taught architecture or the arts and sciences allied therewith. (State names of firms or corporations or public office and of schools or colleges).

1926 - to date.

Partner Laurence & John Scacchetti

Instructor New York Building School - 1929-31 on Economics of Plan and Municipal Regulations.

BUSINESS AFFILIATIONS

15. I list below other business in which I participate or own an interest, and the extent of such participation or interest.

Balosca Holding Corporation, 721 Palisade Avenue, Union City, N.J.
Real Estate Holdings - 10% of stock.

PRESENT OR PREVIOUS MEMBERSHIPS IN ARCHITECTURAL ORGANIZATIONS

- 16. Member of Institute from to
17. Junior of Institute from to
18. Associate of New York Chapter from 1938 to date
19. Junior Associate of Chapter from to
20. Student Associate of Chapter from to
21. Member of State Organization in from to

ENDORSEMENT BY PROPOSERS

(The two proposers must be corporate members of The Institute in good standing.)

I, the undersigned, do hereby certify that I have read the statements made hereinabove by the applicant and believe them to be correct. I vouch for his honorable standing in this community and in his profession, and I believe he is fully qualified for membership and I propose him therefor.

I have known the applicant for 2 years.

Signed [Signature]
Proposer

OLD LYME, CONN.
Address
Mile Creek Rd.

I have known the applicant for 46 years.

Signed [Signature]
Proposer

610-16 St Union City N.J.
Address

LAURENCE & JOHN SCACCHETTI THE AMERICAN
ARCHITECTS AND ENGINEERS INSTITUTE OF ARCHITECTS
610 SIXTEENTH STREET 1946 OCT 25 PM 2:30
UNION CITY, NEW JERSEY

WASHINGTON, D. C. PHONE: UNION 3-0413
UNION 7-1585

October 22, 1946

The Secretary,
The American Institute of Architects,
1741 New York Avenue,
N. W. Washington, 6, D. C.

Dear Sir:

My application for Institute Membership,
accompanied by check for \$10.00, is transmitted herewith
for consideration by your committee.

I shall be pleased to forward such supplementary
data as required, and trust that it will be acted upon
favorably.

Very truly yours,

John Scacchetti

JS:kg
Enc.

THE AMERICAN INSTITUTE OF ARCHITECTS
THE OCTAGON, WASHINGTON, D. C.

COPY

Application
Approved

October 29, 1946

Dear Mr. Scacchetti:

Your application for membership in The Institute and its New York Chapter, dated October 22, 1946, was received here on October 25th, with your check for \$10.00 attached. Your desire to become a member of The Institute is appreciated by The Board.

It is noted from your application that your legal address and office are in New Jersey.

Under the by-laws of The Institute each member must be assigned to a chapter in whose territory he has his legal address or principal place of business.

It would appear, therefore, that your application should be submitted through the New Jersey Chapter, instead of the New York Chapter as you request.

Upon hearing further from you on the above-mentioned item, we shall be glad to take such action on your application as is indicated.

Sincerely yours,

Executive Director

Mr. John Scacchetti
1914 Palisade Avenue
Union City, New Jersey

ECK/ck

cc to: Proposers - Mr. Fritz Steffens, A.I.A.
Mr. Laurence Scacchetti, A.I.A.
Secretary - New York Chapter, A.I.A.
New Jersey Chapter, A.I.A.

LAURENCE & JOHN SCACCHETTI
ARCHITECTS AND ENGINEERS
610 SIXTEENTH STREET
UNION CITY, NEW JERSEY

THE AMERICAN
INSTITUTE OF ARCHITECTS
1946 NOV -4 AM 9:03
WASHINGTON, D. C.

PHONE: UNION 3-0413
UNION 7-1585

November 1, 1946

Mr. Edward C. Kemper, Executive Director,
The American Institute of Architects,
1741 New York Avenue, N. W.,
Washington, 6, D. C.

Dear Mr. Kemper:

The points raised in your letter of
October 29th, were discussed with Miss Waters, the Executive
Secretary of the New York Chapter, prior to submitting my
application.

My brother and I maintained an office in
New York until 1942, when, because of wartime building
restrictions, it was discontinued for the duration, and for
purposes of continued identity, the address of his residence
was used. Up to the first of this year, I was associated
in the offices of Kelly & Gruzen at 220 Broadway, New York,
and withdrew for hospitalization. Since then, I have not
been very active, but it is the intention, when space is
more readily available, to resume practice in New York.

I trust that the Board will consider the
foregoing favorably in their decision.

Yours sincerely,

John Scacchetti

JS:kg

THE AMERICAN INSTITUTE OF ARCHITECTS

THE OCTAGON, WASHINGTON, D. C.

COPY

*Application
Suspense*

November 6, 1946

Dear Mr. Scacchetti:

Responding to yours of November 1st, at hand on the 4th, with respect to chapter assignment upon your election to The Institute:

Under the present By-laws of The Institute, every applicant must be assigned upon election to the chapter in whose territory he resides or has his principal place of business, with a further provision that he may elect to be assigned to any chapter of The Institute in the same state in which he resides or has his principal place of business.

This leaves us with no choice, so far as the record here indicates, with respect to your chapter assignment and we will be obliged to assign you to the New Jersey Chapter.

However, you may maintain an unassigned membership in the New York Chapter if you so desire.

We trust that you will accept assignment to the New Jersey Chapter, with the assurance that should you return to New York an immediate transfer will be made by The Institute.

Sincerely yours,

Executive Director

Mr. John Scacchetti
610 Sixteenth Street
Union City, New Jersey

ECK/ck

cc to: Proposers - Mr. Fritz Steffens, A.I.A.
Mr. Laurence Scacchetti, A.I.A.
Secretary - New York Chapter, A.I.A.
New Jersey Chapter, A.I.A.

COPY TO

FILES

PRESIDENT

SECRETARY

TREASURER

LAURENCE & JOHN SCACCHETTI
ARCHITECTS AND ENGINEERS
610 SIXTEENTH STREET
UNION CITY, NEW JERSEY

THE AMERICAN
INSTITUTE OF ARCHITECTS
NOV 15 AM 2:39
WASHINGTON, D. C.

PHONE: UNION 3-0413
UNION 7-1585

November 13, 1946

Mr. Edward C. Kemper,
Executive Director,
The American Institute of Architects,
1741 New York Avenue, N.W.,
Washington 6, D.C.

Dear Mr. Kemper:

I have been considering the Institute rulings on membership outlined in your letter of November 6th, and have come to the conclusion that it will be best for me to accept assignment to the New Jersey Chapter at this time, rather than to wait until my offices are re-established in New York.

In this manner I will not be pressed for time, and with an unassigned membership in the New York Chapter I can still be kept informed on their proceedings.

I deeply appreciate your interest, and I look forward to the acceptance of my application for membership in the A.I.A.

Sincerely yours,

John Scacchetti

JS/dz

1339
1-46



THE AMERICAN INSTITUTE OF ARCHITECTS AP No 4840
1946 OCT 31 AM 9:01
WASHINGTON, D. C.

THE AMERICAN INSTITUTE OF ARCHITECTS
THE OCTAGON, WASHINGTON, D. C.
Office of The Secretary

RECORD OF REGISTRATION
OF
John Scacchetti, Union City, N.J.
(Name of Applicant)

SECRETARY,
BOARD OF ARCHITECTURAL EXAMINERS,
Newark, New Jersey
Address

Dear Sir:

The above named applicant for membership in The American Institute of Architects is an architect practicing in your state.

To qualify for such membership, an applicant, if resident in a state having registration or licensing laws for architects, must be registered or licensed by the state to practice architecture therein.

Will you please answer the following questions relating to the applicant's registration, to assist The Institute in determining his eligibility for membership? A duplicate of the form is enclosed for your files.

Date October 29, 19 46 Alexander C. Robinson III
Secretary

1. Is the applicant registered or licensed to practice architecture in your state? yes
2. Was his registration or licensing by examination?.....or by exemption?.....
3. What was the scope of the examination? Board examination
4. What was the period of the examination?.....days. Written examination.....hours; Oral examination.....hours.
5. When examined, did applicant have a certificate from the National Council of Architectural Registration Boards? no. If so, give Certificate No.....
6. Date of last registration June 22, 1946 Registration No. 674 Is it current? yes

Gilbert C. Higby
(Signature of Secretary of Board)

Date Oct. 30, 19 46 New Jersey State Board of Architects
(Name of Board)

THE AMERICAN INSTITUTE OF ARCHITECTS ARCHIVES For information or study purposes only. Not to be recopied, quoted, or published without written permission from the AIA Archives, 1735 New York Ave. NW, Washington, DC 20006

339
27-46

THE AMERICAN
INSTITUTE OF ARCHITECTS
1946 NOV -4 AM 9:26
WASHINGTON, D. C.



R
AP No

RECEIVED 4840
OCT 30 1946
Finance Division

THE AMERICAN INSTITUTE OF ARCHITECTS
THE OCTAGON, WASHINGTON, D. C.
Office of The Secretary

RECORD OF REGISTRATION

OF

John Scacchetti, Union City, N.J.

(Name of Applicant)

RECEIVED
OCT 31 1946
PROF. EXAMINATIONS
BUREAU

SECRETARY,
BOARD OF ARCHITECTURAL EXAMINERS,
Albany, New York
Address

Dear Sir:

The above named applicant for membership in The American Institute of Architects is an architect practicing in your state.

To qualify for such membership, an applicant, if resident in a state having registration or licensing laws for architects, must be registered or licensed by the state to practice architecture therein.

Will you please answer the following questions relating to the applicant's registration, to assist The Institute in determining his eligibility for membership? A duplicate of the form is enclosed for your files.

Date October 29, 19 46

Alexander C. Robinson III
Secretary

1. Is the applicant registered or licensed to practice architecture in your state? Secured
2. Was his registration or licensing by examination? yes or by exemption? no
3. What was the scope of the examination? Issued January 30, 1936 on the basis of having passed a written exam in Arch Design, Arch Engineering, Hist. + Theory of Arch and Arch Practice + Equipmen
4. What was the period of the examination? 4 days. Written examination 36 hours; Oral examination hours.
5. When examined, did applicant have a certificate from the National Council of Architectural Registration Boards? . If so, give Certificate No.
6. Date of last registration Sept 1, 19 46 Registration No. 4748 Is it current? yes

H R Field
(Signature of Secretary of Board)

Date Nov 1, 19 46

New York State Education Department
(Name of Board)

THE AMERICAN INSTITUTE OF ARCHITECTS ARCHIVES For information or study purposes only. Not to be recopied, quoted, or published without written permission from the AIA Archives, 1735 New York Ave. NW, Washington, DC 20006



No AP 4840

THE AMERICAN INSTITUTE OF ARCHITECTS
THE OCTAGON, WASHINGTON, D. C.
Office of The Secretary

THE AMERICAN
INSTITUTE OF ARCHITECTS
JAN -4 AM 11:32
WASHINGTON, D. C.

FINAL

NOTICE OF APPLICATION FOR MEMBERSHIP

TO EXECUTIVE COMMITTEE

Name of Chapter New Jersey Chapter, A.I.A.

Name of Applicant John Scacchetti

Date of Application October 22, 19 46.

Duplicate application filed with above named Chapter on October 19

Period for Chapter's action on application ends on January 14, 19 47. FINAL DATE

The time for your action on the application of the applicant above named was fixed in the Notice of Application for Membership heretofore sent you. That time has expired and your recommendation has not been received. In accordance with the provisions of Chapter II, Article 1, Section 2 (c-1) of the by-laws of The Institute, you are hereby notified that if your recommendation is not received on or before the final date fixed above, The Board of The Institute will proceed with the application without your recommendation and, if it admits the applicant to membership, will assign him to membership in your Chapter.

The Board will appreciate your recommendation.

Date December 30, 19 46.

Alexander C. Robinson III
Secretary.

✓ Mr. Fairweather:

We are assuming that the duplicate of Mr. Scacchetti's application has been forwarded to you by Miss Waters.

It was and has been referred to our Membership Committee for the usual report. Kindly do nothing in the matter until you hear from us. A.I.A. Antoinette 1-2-46

THE AMERICAN INSTITUTE OF ARCHITECTS ARCHIVES For information or study purposes only. Not to be recopied, quoted, or published without written permission from the AIA Archives, 1735 New York Ave. NW, Washington, DC 20006



~~DUPLICATE~~
Original
THE AMERICAN INSTITUTE OF ARCHITECTS
1947 MAR -7 AM 9:01
WASHINGTON, D. C.

Name of Chapter
THE AMERICAN INSTITUTE OF ARCHITECTS

New Jersey

FAVORABLE RECOMMENDATION OF CHAPTER
ON APPLICATION FOR MEMBERSHIP

TO BOARD OF DIRECTORS,
THE AMERICAN INSTITUTE OF ARCHITECTS:

I, the undersigned *Secretary* of The *New Jersey* Chapter,
The American Institute of Architects, do hereby certify that the following is a true copy of a
resolution adopted by the Executive Committee of this Chapter at a duly called meeting thereof
held on *February 13* 19*47*, vouching for the honorable standing of
John Louis Scacchetti in the community, and
recommending his admission to membership in The Institute:

RESOLUTION

"Whereas, *John Scacchetti* an architect having his
legal residence principal place of business within the territory of this
Chapter duly applied on *Oct. 22* 19*47* for membership in The
American Institute of Architects; and

"Whereas, the Executive Committee of this Chapter has examined the
statements made by him in his application for such membership and believes
that the statements are true and correct and that the applicant is an architect
of integrity and ability and of honorable standing in this community and
among his fellow architects and able to undertake the financial obligations of
such membership to The Institute and this Chapter; therefore be it

"Resolved, That the *New Jersey* Chapter,
The American Institute of Architects, vouches for the honorable character
and standing of an applicant for admission
to membership in The Institute, believes him able to undertake the financial
obligations of that membership, and recommends to The Board of Directors of
The Institute his admission to membership in The Institute and this Chapter."

Date *Feb. 13* 19 *47* *Clément W. Jamvater*

~~President~~
~~Secretary~~

(Strike out title not applicable)

Type in name of officer and chapter.

Type in dates and name of applicant.

Type in name of applicant. Strike out the words "legal residence" or "principal place of business" which ever are not applicable.

Type in name of chapter.

Type in name of applicant.

THE AMERICAN INSTITUTE OF ARCHITECTS
THE OCTAGON, WASHINGTON, D. C.

COPY

April 11, 1947

Dear Miss Waters:

We are in receipt of the favorable action by The Board of Examiners on the application of Mr. John Scacchetti, for corporate membership in The Institute and assignment to the New Jersey Chapter.

Mr. Scacchetti states that he has been an associate of the New York Chapter from 1938. We shall appreciate it if you will advise us if there are any outstanding dues owed by Mr. Scacchetti. Under established procedure, if there is any such indebtedness, it should be settled before the application can receive final action by The Secretary.

Sincerely yours,

Executive Director

Miss Dorothea Waters, Executive Secretary
New York Chapter, A.I.A.
115 East 40th Street
New York 16, New York

K/k

Sent via air mail

PERRY COKE SMITH
MORRIS B. SANDERS
THEODORE J. YOUNG

PRESIDENT
VICE-PRESIDENT
SECRETARY



ROBERT W. MCLAUGHLIN, JR. TREASURER

DOROTHEA WATERS EXECUTIVE SECRETARY

NEW YORK CHAPTER
THE AMERICAN INSTITUTE OF ARCHITECTS
115 EAST 40th STREET, NEW YORK 16

April 14, 1947

Mr. Edward C. Kemper, Executive Director
American Institute of Architects,
1741 New York Avenue, N. W.,
Washington 6, D. C.

Dear Mr. Kemper:

In reply to your letter of April 11th
with respect to Mr. John Scacchetti, Mr. Scacchetti resigned
as of January 1, 1947 in order to apply through the New Jersey
Chapter for AIA membership. He resigned in good standing.

Yours sincerely,

Executive Secretary

DW:MB

THE AMERICAN INSTITUTE OF ARCHITECTS

THE OCTAGON, WASHINGTON, D. C.

COPY

April 18, 1947

Dear Mr. Scacchetti:

The Secretary is happy to inform you that your application for membership in The Institute was acted on favorably by The Board of Directors and that you were admitted to corporate membership in The Institute and assigned to membership in the New Jersey Chapter, effective April 18, 1947. You will be a member of that Chapter, or of some other chapter if you later transfer thereto, until your membership in The Institute terminates.

Your certificate of membership, duly executed by the Officers of The Institute, will be sent in due course.

The Board of Directors welcomes you to membership in The Institute and The Secretary's office is at your service to the extent of its powers.

The policies and activities of The Institute are developed largely from problems arising within the chapters. By taking an active part in your Chapter affairs, you will contribute to the advancement of the objects of The Institute and will increase the benefits to be derived from Institute membership.

We bespeak your active cooperation.

Sincerely yours,

Alexander C. Robinson III

Secretary

Mr. John Scacchetti, A.I.A.
1914 Palisade Avenue
Union City, New Jersey

ACR/kk
Enclosure

CC to: Proposers - Mr. Fritz Steffens, A.I.A.
Mr. Laurence Scacchetti, A.I.A.

THE AMERICAN INSTITUTE OF ARCHITECTS
LAURENCE & JOHN SCACCHETTI
ARCHITECTS AND ENGINEERS
610 SIXTEENTH STREET
UNION CITY, NEW JERSEY
WASHINGTON, D.C.

PHONE: UNION 3-0413
UNION 7-1585

file

April 25, 1947

Mr. Alexander C. Robinson III,
The American Institute of Architects,
1741 New York Avenue, N.W.
Washington 6, D.C.

Dear Mr. Robinson:

I was delighted to receive your notification of the 18th, of my admission to membership in the Institute as of that date.

Please be assured of my intention to merit the honor of this membership, and of my cooperation in the causes of the Institute and the Architectural profession.

With many thanks for your courtesy, believe me,

Yours sincerely,
John Scacchetti
John Scacchetti

JS/dz

THE AMERICAN INSTITUTE OF ARCHITECTS ARCHIVES For information or study purposes only. Not to be recopied, quoted, or published without written permission from the AIA Archives, 1735 New York Ave. NW, Washington, DC 20006



NEW JERSEY CHAPTER

THE AMERICAN INSTITUTE OF ARCHITECTS

120 HALSTED STREET, EAST ORANGE, NEW JERSEY, ORANGE 2-7900

ADOLPH R. SCRIMENTI
President
SOMERVILLE

HOWARD L. MC MURRAY
1st Vice President
ELIZABETH

ARTHUR E. RIGOLO
2nd Vice President
CLIFTON

ROBERT R. CUEMAN
Treasurer
SUMMIT

ROBERT L. DENNIS
Secretary
ELIZABETH

MRS. HELEN T. SCHNEIDER
EXECUTIVE
SECRETARY

OCTOBER 30, 1961

JURY OF FELLOWS
THE AMERICAN INSTITUTE OF ARCHITECTS
THE OCTAGON
1735 NEW YORK AVENUE, N.W.
WASHINGTON 6, D.C.

RE: JOHN SCACCHETTI
NOMINATION FOR FELLOWSHIP

GENTLEMEN:

ENCLOSED HEREWITH PLEASE FIND A.I.A. FORM H-503 TOGETHER WITH SUPPLEMENTARY SHEETS THERETO, A COPY OF PATENT 2,233,901 AND A LETTER FROM THE SECRETARY OF THE N.J. CHAPTER A.I.A. CONCERNING MR. SCACCHETTI'S STANDING.

IF ANY FURTHER COPIES OF THIS MATERIAL ARE DESIRED PLEASE DO NOT HESITATE TO CONTACT THE WRITER.

VERY TRULY YOURS,

ADOLPH R. SCRIMENTI, PRESIDENT
NEW JERSEY CHAPTER, A.I.A.

JAS:HK
ENC.

Scacchetti

November 13, 1961

Mr. Adolph R. Scrimenti, President
New Jersey Chapter, A.I.A.
205 West Main Street
Somerville, New Jersey

Dear Mr. Scrimenti:

On behalf of The Jury of Fellows, this will acknowledge receipt of the Nomination for Advancement to Fellowship of Mr. John Scacchetti, A.I.A., which is in order with the following exception:

In case you are not aware, every nomination must be accompanied by a photographic exhibits of the nominee's architectural work, regardless of the category under which the nomination is made.

Therefore, we are returning to you, herewith, page 3 of Mr. Scacchetti's nomination and it would be appreciated if you would fill in the last column indicating which exhibits will be submitted to The Jury of Fellows.

Such exhibits must be received not later than January 1, 1962.

Sincerely yours,

(Miss) Florence H. Gervais
Secretary to The Jury of Fellows

FHG:MM

enclosure



NEW JERSEY CHAPTER

THE AMERICAN INSTITUTE OF ARCHITECTS

120 HALSTED STREET, EAST ORANGE, NEW JERSEY, ORANGE 2-7900

ADOLPH R. SCRIMENTI
President
SOMERVILLE

HOWARD L. MC MURRAY
1st Vice President
ELIZABETH

ARTHUR E. RIGOLO
2nd Vice President
CLIFTON

ROBERT R. CUEMAN
Treasurer
SUMMIT

ROBERT L. DENNIS
Secretary
ELIZABETH

MRS. HELEN T. SCHNEIDER
EXECUTIVE
SECRETARY

NOVEMBER 22, 1961

MISS FLORENCE H. GERVAIS
SECRETARY TO THE JURY OF FELLOWS
AMERICAN INSTITUTE OF ARCHITECTS
1735 NEW YORK AVE., N.W.
WASHINGTON 6, D.C.

DEAR MISS GERVAIS:

ENCLOSED HERewith PLEASE FIND CORRECTED SHEET #3 WHICH
NOW CONTAINS THE INFORMATION REQUESTED IN YOUR LETTER
OF NOVEMBER 13, 1961, REGARDING JOHN SCACCHETTI'S NOM-
INATION FOR ADVANCEMENT TO FELLOWSHIP.

THANK YOU VERY MUCH FOR THE COURTESY EXTENDED US.

VERY TRULY YOURS,

ADOLPH R. SCRIMENTI, A.I.A.
PRESIDENT, N.J. CHAPTER A.I.A.
N.J. SOCIETY OF ARCHITECTS

ARS:HK
ENC.

NOV 27 1961

MISS FLORENCE H. GERVAIS
SECRETARY TO THE JURY OF FELLOWS
THE AMERICAN INSTITUTE OF ARCHITECTS
1735 NEW YORK AVE., N.W.
WASHINGTON 6, D.C.

DEAR MISS GERVAIS:

ENCLOSED HEREWITH PLEASE FIND THE FOLLOWING MATERIALS TO COMPLETE THE SUBMISSION OF THE SPONSORSHIP OF JOHN SCACCHETTI FOR NOMINATION TO FELLOWSHIP IN THE INSTITUTE:

1. FIFTEEN PHOTOGRAPHS AS SET FORTH IN HIS ORIGINAL SUBMISSION.
2. LETTERS OF ENDORSEMENT IN A PACKAGE WHICH WE HAVE LEFT LOOSE FOR YOUR EASY REFERENCE.
3. AN EXECUTED CERTIFICATE OF AUTHORSHIP COVERING THE DESIGN SUBMISSION OF A CANDIDATE.

I TRUST THAT THESE ENCLOSURES WILL COMPLETE OUR SUBMISSION ON BEHALF OF MR. SCACCHETTI. IN THE EVENT THERE IS ANY ADDITIONAL INFORMATION DESIRED, PLEASE DO NOT HESITATE TO CONTACT EITHER MYSELF OR MRS. SCHNEIDER OUR EXECUTIVE SECRETARY.

VERY TRULY YOURS,

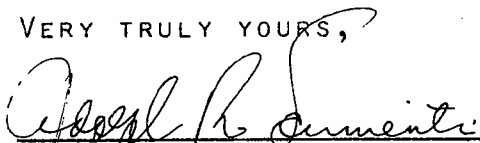

ADOLPH R. SCRIMENTI, A.I.A., PRESIDENT
NEW JERSEY CHAPTER, A.I.A., AND
NEW JERSEY SOCIETY OF ARCHITECTS

ARS:HK
ENC.

DEC 29 1961

THE AMERICAN INSTITUTE OF ARCHITECTS ARCHIVES For information or study purposes only. Not to be recycled, quoted, or published without written permission from the AIA Archives, 1735 New York Ave. NW, Washington, DC 20006

300-1-01



No. NF 917
Received Oct. 31 196
Voted On March 1 196
Voted On _____ 19____
Voted On _____ 19____
Granted _____ 19____

THE AMERICAN INSTITUTE OF ARCHITECTS
JURY OF FELLOWS

No. M 917

NOMINATION FOR FELLOWSHIP

CASE RECORD

1. Name of Nominee John Scacchetti Date of Nomination Oct. 27 19 61
2. Address of Nominee 310 Monastery Place, Union City, New Jersey
3. Nominee's firm John Scacchetti, A.I.A., Architect
4. Nominee's principal place of business Hudson Trust Bldg. - 415-32nd St.
Union City, New Jersey
5. Nominee's Chapter New Jersey Chapter, A.I.A.
6. Nominee's State Organization NONE
7. Nominee admitted to Institute April 18, 1947
8. Nominee has been in good standing in Institute from 4 19 47 to January 1 19 62
9. Nominee's age 61 Birthplace New York, New York
10. Nominators: Executive Committee, New Jersey Chapter, A.I.A.
 - ✓ (1) Adolph R. Scrimiento — ✓ (4) Robert Cueman —
 - ✓ (2) Howard L. McMurray — ✓ (5) Robert L. Dennis —
 - ✓ (3) Arthur E. Rigolo —
11. Achievement Service to The Institute

J-6-60

(Nominators leave blank)

CONFIDENTIAL



THE AMERICAN INSTITUTE OF ARCHITECTS

NOMINATION FOR FELLOWSHIP

BY
CHAPTER

THE JURY OF FELLOWS, A.I.A.
The Octagon, 1735 New York Avenue, N. W.
Washington 6, D. C.

Date OCTOBER 27 19 61

The Executive Committee of this Chapter, at a duly called meeting on MARCH 9 1961
nominated* JOHN SCACCHETTI
member of this Chapter, for fellowship in The Institute. We enclose evidence of the qualifications of
the nominee for the fellowship on which the nomination was based and certify the resolution is as
follows:

*Type in full name.

"Whereas, this Executive Committee believes* JOHN SCACCHETTI
a member of this Chapter, has made so notable a contribution to the advancement of the pro-
fession because of his achievement in** SERVICE TO THE INSTITUTE
that he is worthy of fellowship in The Institute; and

*Type in full name.

**Type in "Design," "Science of Construction," "Literature," "Education," "Service to The Institute," or "Public Service," as is appropriate.

"Whereas, said member has been in good standing in this Chapter for† FOURTEEN (14)
years prior to this date; therefore be it

†Type in number of years.

"Resolved, That‡ THE NEW JERSEY Chapter,
The American Institute of Architects, does hereby nominate* JOHN SCACCHETTI

‡Type in name of Chapter.

*Type in full name.

for fellowship in The Institute, and the President and the Secretary be and hereby are
authorized and directed to prepare the nomination papers and forward them to The Jury of
Fellows of The Institute and to do all things proper to forward said nomination."

Joseph R. Scimenti PRESIDENT
1ST V. PRES.
2ND V. PRES.
TREASURER
Secretary.

THE AMERICAN INSTITUTE OF ARCHITECTS ARCHIVES For information or study purposes only. Not to be recopied, quoted, or published without written permission from the AIA Archives, 1735 New York Ave. NW, Washington, DC 20006

THE NOMINATORS SHOULD SEE THAT LETTERS OR DATA ARE SENT TO THE JURY OF FELLOWS IN SUPPORT OF THIS NOMINATION. ALL SUCH COMMUNICATIONS SHALL BE PRIVILEGED AND NO COPIES SHOULD BE GIVEN TO OTHERS.

OCT 31 1961

Nominatee
before c
includi

BIOGRAPHICAL STATISTICS

1. Nominee's full name JOHN SCACCHETTI
2. Nominee is a natural ~~born~~ citizen of THE UNITED STATES
3. Nominee's legal residence 310 MONASTARY PLACE, UNION CITY, N.J.
4. Nominee's firm name JOHN SCACCHETTI, A.I.A., ARCHITECT
5. Nominee's principal place of business, address HUDSON TRUST BUILDING, 415-32ND STREET, UNION CITY, N.J.

2. Strike out in-
appropriate word
and write in name
of Country.

6. Nominee is registered or licensed to practice architecture by NEW JERSEY (1927),
NEW YORK (1936), N.C.A.R.B. (1946)

6. Type in "N.C.
A. R. B." or
name of State
Board, as case
may be.

7. Nominee is engaged in practice of architecture as a practicing architect—teacher in architecture—
teacher in science of construction—public official—retired.

7. Strike out in-
appropriate
words.

8. Born DEC. 25, 1900 Place of birth NEW YORK, N.Y.

8. Type in date
of birth and city
and Country.

9. Nominee's schools, colleges and universities:

	Location	No. of Years	Year of Graduation	Degree
High School	WEST HOBOKEN HIGH SCHOOL	1	1914	
Private School	NEW YORK PREPARATORY	4	1936	
College or University	MECHANICS INSTITUTE	3	1919	
	CITY COLLEGE OF N.Y.	2		
College or University	COLUMBIA UNIVERSITY	2		
Post Graduate at				
Scholarships held				

10. Other data concerning nominee's record.

10. Type in im-
portant experi-
ences during em-
ployment or ad-
ditional statistics
of importance in
nominee's record.

SEE ATTACHED SHEET 2A

Nominators should read "Principles Underlying the Bestowal of Fellowships", Institute Document No. 9 before completing this nomination. Additional sheets may be inserted to supplement any page, 3 to 7, inclusive. Use typewriting only.

NOMINEE'S ACHIEVEMENT IN ARCHITECTURAL DESIGN

1. Works

Type (a) Commercial (b) Monumental (c) Domestic (d) Special	Identification of Work	Location of Work (City)	(State)	Completed Construction Work (Year)	Photographs Drawings, or Sketches Submitted
A	MEDICAL OFFICE BLDG.	TEANECK	N.J.	1955	1
A	AUTO.SALES & SERVICE BLDG.	JERSEY CITY	N.J.	1953	2
A	SMITH CORONA BLDG.	ENGLEWOOD	N.J.	1957	1
A	MINN.MINING & MFG. OFFICE & WAREHOUSE	RIDGEFIELD	N.J.	1948	1
C	BERRY RESIDENCE	BALD MOUNTAIN	N.Y.	1938	2
A	SHEFFCO OFFICE & MFG. BLDG.	FAIRVIEW	N.J.	1954	1
A	ECCO HIGH FREQUENCY BLDG.	NO. BERGEN	N.J.	1955	1
A	GROOVE PIN CORP.BLDG.	RIDGEFIELD	N.J.	1953	1
C	J.V.BONANNO RES.	TENAFLY	N.J.	1941	2
C	S.F.BONANNO RES.	ENGLEWOOD	N.J.	1952	1
C	TWIN RESIDENCES	WOODRIDGE	N.J.	1951	1
A	GUTTENBERG SAVINGS	GUTTENBERG	N.J.	1958	1

Under column
headed "Type"
type in (a), (b),
(c), or (d), as
the case may be.

Type in last col-
umn to right the
number submitted
in each case.

2. Describe nominee's notable work in design, to bring out the particular achievements the nominators believe have notably contributed to the advancement of the profession.

SEE SUPPLEMENTARY SHEET 3A

NOV 27 1981

OCT 31 1981

50-A-41271

NOMINEE'S ACHIEVEMENT IN SCIENCE OF CONSTRUCTION

1. CONSTRUCTION WORK

<i>Type of Work Constructed</i>	<i>Identification of Work</i>	<i>Location of Work</i>	<i>Completed Construction Work (Year)</i>	<i>Photographs, Drawings, or Sketches Submitted</i>
-------------------------------------	-----------------------------------	-----------------------------	---	---

Type in last
column to right
the number sub-
mitted in each
case.

2. BOOKS, TREATISES, OR ARTICLES WRITTEN

<i>Subject Title</i>	<i>Where Published</i>	<i>Date Published</i>
----------------------	------------------------	-----------------------

3. Describe nominee's notable work in the science of construction and any recognition thereof by other societies, to bring out the particular achievements the nominators believe have notably contributed to the advancement of the profession.

IN 1941 NOMINEE OBTAINED PATENT No. 2233901 ON A SYSTEM OF ADAPTABLE ELEMENTS FOR TEMPORARY OR PERMANENT STRUCTURAL FRAMING, A COPY OF WHICH IS ENCLOSED.

NOMINEE'S ACHIEVEMENT IN EDUCATION AND LITERATURE

1. EDUCATION WORK

(List the degrees and the educational positions held by the nominee, and bring out clearly the nominee's signal work and its particular force and influence which the nominators believe to be a notable contribution to the advancement of the profession, and state evidences of recognition of such work by pupils, the profession, other societies, or the public.)

1929-31 INSTRUCTOR IN BUILDING LAWS - NEW YORK BUILDING SCHOOL

2. LITERARY WORK

(List the original written works of the nominee and state clearly the particular force and influence of that work which the nominators believe to be a notable contribution to the advancement of the profession, and state evidences of recognition of such work by other societies, the profession, educational institutions or the public.)

*Book, Treatise
or Article*

Subject

*Name of Book or Periodical
Containing Work*

*Year Work
Published*

THE AMERICAN INSTITUTE OF ARCHITECTS ARCHIVES For information or study purposes only. Not to be recycled, quoted, or published without written permission from the AIA Archives, 1735 New York Ave. NW, Washington, DC 20006

MAY 31 1961

NOMINEE'S ACHIEVEMENTS IN SERVICE TO THE INSTITUTE

1. State fully the nominee's signal service to The Institute, his chapter, or his state organization, or to the profession, which the nominators believe has notably contributed to the advancement of the profession, and list the offices in architectural organizations occupied by the nominee and the period of each.

- 1938 BECAME ASSOCIATE MEMBER NEW YORK CHAPTER, A.I.A.
1947 BECAME CORPORATE MEMBER A.I.A., N.J.CHAPTER.
1950 BECAME MEMBER NEW JERSEY SOCIETY OF ARCHITECTS.
1951-53 MEMBER PUBLIC RELATIONS COMM. MEMBER CONVENTION COMM.
AS CHAIRMAN, ARRANGEMENTS COMM., N.J.CHAPTER, A.I.A.
AND N.J.SOCIETY OF ARCHITECTS.
1952-58 DIRECTOR NEW JERSEY CHAPTER A.I.A.
1952-53 CHAIRMAN PROGRAM COMM., N.J.CHAPTER A.I.A. AND N.J.SOCIETY
OF ARCHITECTS, MEMBER CONVENTION COMMITTEE.
1954-55 CHAIRMAN A.I.A.-P.C.COMM. MEMBER STATE BOARD JURY COMM.,
CONVENTION COMMITTEE, N.J.CHAPTER A.I.A. AND N.J.SOCIETY
OF ARCHITECTS.
1955-56 CHAIRMAN CONVENTION COMM., N.J. CHAPTER A.I.A. AND N.J.
SOCIETY OF ARCHITECTS. DELEGATE TO NATIONAL CONVENTION.
1956-57 HONORARY CHAIRMAN CONVENTION COMM. N.J.CHAPTER A.I.A.
AND N.J.SOCIETY OF ARCHITECTS. DELEGATE TO NATIONAL CON-
VENTION.
1957-58 SECRETARY NEW JERSEY CHAPTER A.I.A. AND N.J.SOCIETY OF
ARCHITECTS. HONORARY CHAIRMAN CONVENTION COMM. N.J. CHAPTER
A.I.A. AND N.J. SOCIETY OF ARCHITECTS. DELEGATE TO NATIONAL
CONVENTION.
1958-59 SECOND VICE-PRESIDENT N.J.CHAPTER A.I.A. AND THE N.J. SOCIETY
OF ARCHITECTS. MEMBER LEGISLATIVE AND PROGRAM COMMITTEES.
DELEGATE TO NATIONAL CONVENTION.
1959-60 FIRST VICE-PRESIDENT N.J. CHAPTER A.I.A. AND N.J. SOCIETY
OF ARCHITECTS; CHAIRMAN PROGRAM COMMITTEE; MEMBER LEGISLA-
TIVE COMMITTEE; REPRESENTATIVE TO JOINT BOARD OF ARCHITECTS
AND ENGINEERS. DELEGATE TO NATIONAL CONVENTION.
1960-61 PRESIDENT N.J. CHAPTER A.I.A. AND N.J.SOCIETY OF ARCHITECTS;
REPRESENTATIVE TO JOINT BOARD OF ARCHITECTS AND ENGINEERS.
DELEGATE TO NATIONAL CONVENTION.
1961-62 CHAIRMAN BUDGET FINANCE COMMITTEE; MEMBER EXECUTIVE, AWARDS
AND CITATIONS, CONVENTION, LEGISLATIVE, NOMINATING, URBAN
DESIGN AND TWO SPECIAL COMMITTEES ON CONVENTION LOCATION AND
COMMITTEE FUNCTIONS.
1961 MEMBER BY-LAWS REVISION COMMITTEE, MIDDLE ATLANTIC REGION,
A.I.A.

SEE SUPPLEMENTAL SHEET 6A

SUPPLEMENT TO NOMINEE'S
ACHIEVEMENTS IN SERVICE TO INSTITUTE
(PAGE 6)

1. 1962-63 CHAIRMAN AIA-NCARB LICENSING COMMITTEE
2. 1962-63 MEMBER OF BUDGET, FINANCE AND AUDIT,
COMMITTEE ON COMMITTEES, LEGISLATIVE AND
NOMINATING COMMITTEES.

This page
Received after
July's 1962
meeting

THE AMERICAN INSTITUTE OF ARCHITECTS ARCHIVES For information or study purposes only. Not to be recycled,
quoted, or published without written permission from the AIA Archives, 1735 New York Ave. NW, Washington, DC 20006

2

SUPPLEMENTS TO NOMINEE'S
ACHIEVEMENTS IN PUBLIC SERVICE
(PAGE 7)

1. 1962-63 CHAIRMAN, AIA-NCARB LIAISON COMMITTEE REPRESENTING NCARB.
2. 1962-63 CHAIRMAN, COMMITTEE ON LICENSING FOR THE NCARB.
CHAIRMAN, LEGISLATIVE COMMITTEE, N.J.STATE BOARD OF ARCHITECTS.
MEMBER SPECIAL BOARD REPRESENTING THE N.J.STATE BOARD OF ARCHITECTS.

(This page was
received after
Jury's 1962
Meeting)

2

NOMINEE'S ACHIEVEMENT IN PUBLIC SERVICE

1. List the public offices held by the nominee and the positions of trust held by him in recognition of civic leadership, and state clearly his notable work in public service and the particular influence of that work which the nominators believe to be a notable contribution to the advancement of the profession.

1929 MEMBER - SUBCOMMITTEE ON REVISION OF NEW YORK CITY MULTIPLE DWELLING LAW.

1956-61 NEW JERSEY STATE BOARD OF ARCHITECTS
1957-58 CHAIRMAN PUBLIC RELATIONS COMMITTEE
1957-59 CHAIRMAN BUDGET AUDIT AND FINANCE COMMITTEES
1958-60 CHAIRMAN LEGISLATIVE COMMITTEE
1956-61 DELEGATE TO NATIONAL CONVENTION N.C.A.R.B.

1959 TO DATE: CHAIRMAN NATIONAL LICENSING COMMITTEE OF NATIONAL COUNCIL OF ARCHITECTURAL REGISTRATION BOARDS.

1961 ACCEPTED REAPPOINTMENT TO N.J. STATE BOARD OF ARCHITECTS FOR FIVE YEARS AT SPECIAL REQUEST OF GOVERNOR MEYNER AND ATTORNEY GENERAL FURMAN AS A RESULT OF HIS OUTSTANDING WORK ON McCAMY CASE AND OTHER LICENSING MATTERS.

NOTE: NOMINEE'S NOTABLE ACHIEVEMENTS IN THIS AREA ARE NOTED AND INCORPORATE UNDER SERVICE TO THE INSTITUTE AS THEY ARE INSEPARABLE FROM HIS ACHIEVEMENTS IN THAT CATEGORY.

THE AMERICAN INSTITUTE OF ARCHITECTS ARCHIVES For information or study purposes only. Not to be recycled, quoted, or published without written permission from the AIA Archives, 1735 New York Ave. NW, Washington, DC 20006

11-10-61
-10000
parting

JOHN SCACCHETTI
OCTOBER 27, 1961

1916-1919 JUNIOR DRAFTSMAN - SCHWARTZ & GROSS, NEW YORK, N.Y.

1919-1926 DRAFTSMAN - BLOODGOOD AND SUGARMAN (SUGARMAN & BERGEN)
NEW YORK, N.Y.

BECAME CHIEF DRAFTSMAN, IN CHARGE OF HOTELS, APARTMENTS,
AND INDUSTRIAL BUILDINGS AND IN 1924-25 WAS IN CHARGE OF
1900 RITTENHOUSE SQUARE AND TEMPLE B'NAI JESHURUM IN
PHILADELPHIA FOR THE FIRM.

1926-1927 PARTNERSHIP WITH LAWRENCE SCACCHETTI

1927-1929 CHIEF DRAFTSMAN - WILLIAM L. BOTTOMLEY, NEW YORK, N.Y.

1929-1933 CHIEF DRAFTSMAN AND OFFICE MANAGER - BOTTOMLEY, WAGNER
AND WHITE, NEW YORK, N.Y., IN COMPLETE CHARGE OF ENTIRE
OFFICE. DEVELOPED RIVER HOUSE, WHICH WAS FIRST TOWER
APARTMENT DEVELOPED UNDER NEW MULTIPLE DWELLING LAW WHICH
NOMINEE HELPED DRAFT. INITIATED CROSS-OVER DUPLEX UNITS,
NEW FIRE TOWER PROVISIONS OF THE LAW, ETC.

1933-1939 CHIEF DRAFTSMAN AND OFFICE MANAGER - WM. L. BOTTOMLEY,
NEW YORK, N.Y., IN COMPLETE CHARGE OF OFFICE.

1939-1941 PARTNERSHIP WITH LAWRENCE SCACCHETTI

1941-1946 KELLY AND GRUZEN, NEW YORK, N.Y. - NOMINEE SERVED AS ASSOCIATE
IN CHARGE OF PRODUCTION.

1946 TO DATE - OWN PRACTICE OF ARCHITECTURE. OFFICE HAS BEEN KEPT
SMALL AS NOMINEE WAS RECOVERING FROM SERIOUS ILLNESS
AND MAJOR SURGERY. WORK HAS BEEN VARIED RESIDENTIAL,
COMMERCIAL, AND IN RECENT YEARS LARGELY INDUSTRIAL.

THE AMERICAN INSTITUTE OF ARCHITECTS ARCHIVES For information or study purposes only. Not to be recycled,
quoted, or published without written permission from the AIA Archives, 1735 New York Ave. NW, Washington, DC 20006

100-1059-108
100-1059-109
100-1059-110
100-1059-111
100-1059-112
100-1059-113
100-1059-114
100-1059-115
100-1059-116
100-1059-117
100-1059-118
100-1059-119
100-1059-120
100-1059-121
100-1059-122
100-1059-123
100-1059-124
100-1059-125
100-1059-126
100-1059-127
100-1059-128
100-1059-129
100-1059-130
100-1059-131
100-1059-132
100-1059-133
100-1059-134
100-1059-135
100-1059-136
100-1059-137
100-1059-138
100-1059-139
100-1059-140
100-1059-141
100-1059-142
100-1059-143
100-1059-144
100-1059-145
100-1059-146
100-1059-147
100-1059-148
100-1059-149
100-1059-150
100-1059-151
100-1059-152
100-1059-153
100-1059-154
100-1059-155
100-1059-156
100-1059-157
100-1059-158
100-1059-159
100-1059-160
100-1059-161
100-1059-162
100-1059-163
100-1059-164
100-1059-165
100-1059-166
100-1059-167
100-1059-168
100-1059-169
100-1059-170
100-1059-171
100-1059-172
100-1059-173
100-1059-174
100-1059-175
100-1059-176
100-1059-177
100-1059-178
100-1059-179
100-1059-180
100-1059-181
100-1059-182
100-1059-183
100-1059-184
100-1059-185
100-1059-186
100-1059-187
100-1059-188
100-1059-189
100-1059-190
100-1059-191
100-1059-192
100-1059-193
100-1059-194
100-1059-195
100-1059-196
100-1059-197
100-1059-198
100-1059-199
100-1059-200

FURTHER DESCRIPTION OF THE PROJECTS SUBMITTED, WHICH TYPIFY THE NOMINEES PATIENT AND CAREFUL EFFORTS IN DESIGN UNDER THE SEVERE HANDICAPS OF A SMALL URBAN PRACTICE FOLLOW:

- (A) IN AN AREA DEDICATED TO THE USE OF TRADITIONAL ARCHITECTURE IT WAS A NECESSITY TO ACHIEVE A DESIGN WHICH WOULD BE DISTINCTIVE AND YET FIT IN TO SOME DEGREE WITH THE SURROUNDINGS AND THE THINKING OF BOTH CITIZENS OF THE COMMUNITY AS WELL AS THE ATTITUDE OF THE CLIENTS AND PATIENTS WHO WERE TO USE THE BUILDING. THE STUDY OF TERRAIN AND FENESTRATION PRODUCED A BALANCED STRUCTURE PERMITTING THE LOW END OF THE BUILDING TO BE USED FOR OFFICES WITH AN APPEARANCE OF BEING ABOVE GRADE.
- (B) ON A SITE WITH A DIFFERENCE OF 30'0" BETWEEN STREETS AND FLANKING ONE OF THE HEAVIEST TRAFFICKED HIGHWAYS IN THE UNITED STATES, WITH SERIOUS FOUNDATION PROBLEMS INCLUDING HIGH PRESSURE SEWER LINES, A THREE STORY AUTO SALES & SERVICE BUILDING WAS CONSTRUCTED UTILIZING RAMPS TO PROVIDE ACCESS TO VARIOUS LEVELS. INTENSIVE STUDIES OF GRADES PRODUCED HIGHLY EFFICIENT WORKABLE AREAS WHICH HAVE RECEIVED COMMENDATION FROM THE GENERAL MOTORS CORPORATION, AS WELL AS HIGH PRAISE FROM MANY COMPETITORS.
- (C) A SMALL SALES AND SERVICE BUILDING FOR SMALL BUSINESS MACHINES WAS DESIGNED TO FEATURE THE OFFICES IN SUCH A MANNER AS TO ALLOW FOR CONVERSION INTO AN OFFICE BUILDING THROUGHOUT THE ENTIRE AREA.
- (D) A BUILDING HOUSING THE PRINCIPAL EASTERN OFFICES AND WAREHOUSE FOR THIS COMPANY. UNUSUAL GRADE CONDITIONS POSED PROBLEMS TO ACHIEVE PROPER STORY HEIGHTS AND CLEARANCES AND LOADING LEVELS FOR RAILROAD SIDING AND TRUCKING FACILITIES.
- (E) DESIGNED FOR ERECTION ON EXISTING FOUNDATIONS THE STRUCTURE WAS DESIGNED TO USE MARBLE BRICK, AN EXPERIMENT CONDUCTED WITH THE VERMONT MARBLE COMPANY IN AN ATTEMPT TO FIND A USE FOR MARBLE IN SMALL PIECES REMAINING AFTER CUTTING.
- (F) THIS STRUCTURE OF 45,000 SQ. FT. HOUSES THE EXECUTIVE OFFICES AND IN ADDITION TO THE USUAL MOULDING AND STAMPING DEPARTMENTS HAS A NUMBER OF "SUPER CLEAN" DEPARTMENTS REQUIRING SPECIAL DUST-PROOFING AND AIR CONDITIONING WITH HUMIDITY CONTROL.
- (G) THIS INDUSTRIAL BUILDING ADDITION WAS DESIGNED AS AN ADDITION AND ABOVE A STRUCTURE EXISTING AT THE REAR. THE DESIGN REQUIRED BUILDING ABOVE WHILE DELICATE OPERATIONS INVOLVING ELECTRONIC PARTS MANUFACTURING COULD CONTINUE WITHOUT HINDRANCE OR DAMAGE. THE ADDITION HOUSES A NEEDLE TRADE MANUFACTURER WHOSE REQUIREMENTS INCLUDED WIDE SPANS FOR CLEARANCES NEEDED FOR CUTTING TABLES. A HIGH EMPLOYEE POPULATION POSED PROBLEMS WITH EXITS DUE TO UNUSUAL SITE GRADE CONDITIONS.
- (H) SITE RESTRICTIONS REQUIRED THAT ALL OPERATIONS, INCLUDING EXECUTIVE AND WORKING OFFICES, CLIENT AND PERSONNEL ENTRANCES, POWER PLANT, SHIPPING AND MANUFACTURING DEPARTMENTS, FACE ON THE FRONT OF THE STRUCTURE. AREAS, HEIGHTS AND OTHER MANDATORY REQUIREMENTS WERE FURTHER COMPLICATIONS ENCOUNTERED IN DEVELOPING THE DESIGN.
- (I) A SIMPLE UNPRETENTIOUS DESIGN OF PERIOD ARCHITECTURE.

HYMIDICV
NOMINEE
EQUILIBER

- (J) THIS RESIDENCE WAS DESIGNED TO UTILIZE MATERIALS WHICH WOULD REQUIRE A MINIMUM OF MAINTENANCE OVER THE YEARS. THE RESTRICTIONS IMPOSED BY THE OWNER INCLUDED THE EXCLUSION OF ANY EXTERIOR WOODWORK AND THE MINIMUM OF SURFACES WHICH WOULD REQUIRE PAINT.
- (K) HOMES FOR TWO SISTERS. INCLUSION OF USED BRICK AND OTHER MATERIALS AFFECTED ECONOMIES MAKING IT POSSIBLE FOR BUILDINGS TO BE ERECTED WITHIN BUDGET.
- (L) ACQUISITION OF STORE PROPERTY ON LEFT HALF INCREASED BANK AREA AND NEW FRONT WAS DESIGNED TO INCLUDE BOTH. BOARD OF DIRECTORS WOULD NOT CONSENT TO ALTERING ANY PART OF THE OLD BUILDING ABOVE THE FIRST FLOOR. THE WORK WAS CARRIED ON WITHOUT INTERRUPTION TO THE OPERATION OF THE BANK.

THE AMERICAN INSTITUTE OF ARCHITECTS ARCHIVES For information or study purposes only. Not to be recycled, quoted, or published without written permission from the AIA Archives, 1735 New York Ave. NW, Washington, DC 20006

OCT 31 1961

SHEET 3A CONT'D.

THE NOMINEE HAS A LONG RECORD OF SERVICE TO THE INSTITUTE AND THE PROFESSION, BUT IN ADDITION HAS RENDERED SIGNAL AND EXCEPTIONAL SERVICE IN SEVERAL AREAS:

1. IN 1952-53 AS CHAIRMAN OF THE NEW JERSEY CHAPTER A.I.A. PROGRAM COMMITTEE HE ASSISTED GREATLY IN FORMING THE NEWARK CHAPTER OF THE PRODUCERS COUNCIL AND IN ESTABLISHING IMMEDIATE RELATIONSHIP BETWEEN THE NEW CHAPTER AND THE NEW JERSEY CHAPTER A.I.A. THEREBY FURTHERING BETTER RELATIONS AND UNDERSTANDING BETWEEN PRODUCERS AND ARCHITECTS IN THE STATE OF NEW JERSEY.
2. IN 1953 THE NOMINEE SPONSORED AND FORMED THE HUDSON COUNTY CHAPTER OF THE NEW JERSEY SOCIETY OF ARCHITECTS THEREBY BRINGING INTO SOCIETY MEMBERSHIP AND ACTIVE STATUS MANY ARCHITECTS WHO HAD PREVIOUSLY HAD NO PROFESSIONAL AFFILIATIONS. MANY OF THESE MEN HAVE SINCE BECOME CORPORATE MEMBERS OF THE INSTITUTE. HE SERVED AS PRESIDENT FOR 1953-54.
3. AS PRESIDENT OF THE NEW JERSEY CHAPTER A.I.A. (1960-61) THE NOMINEE BROADENED CONTACTS AND LIAISON WITH OTHER PROFESSIONAL AND STATE ORGANIZATIONS, GREATLY CONTRIBUTING THEREBY TO THE STATURE AND ENHANCEMENT OF THE INSTITUTE AND THE ARCHITECTURAL PROFESSION. HE ESTABLISHED DIRECT LIAISON WITH THE STATE BAR ASSOCIATION, STATE REALTORS ASSOCIATION AND STATE ASSOCIATION OF BUILDING OFFICIALS. THE N.J. CHAPTER AND SOCIETY BECAME A MEMBER OF THE ASSOCIATION OF ALLIED ORGANIZATIONS DIRECTLY UNDER HIS LEADERSHIP.
4. THE NOMINEES GREATEST CONTRIBUTION TO THE INSTITUTE, THE PROFESSION, AND TO THE PUBLIC HAS BEEN IN IMPROVING THE LEGAL STATUS OF THE PROFESSION. BOTH AS A MEMBER OF THE NEW JERSEY CHAPTER A.I.A. AND THE NEW JERSEY STATE BOARD OF ARCHITECTS HE HAS SPONSORED AND SEEN ENACTED LEGISLATION TO CLARIFY THE LEGAL REQUIREMENTS FOR THE PRACTICE OF ARCHITECTURE AND THE IMPLEMENTATION OF THOSE REQUIREMENTS. (R.S. 45:3) HE WAS FURTHER RESPONSIBLE FOR THE DRAFTING AND INTRODUCTIONS OF BILLS AMENDING NEW JERSEY R.S. 40:55-52, 45:3-10 AND 52:32-3, DEALING WITH THE REQUIREMENTS OF FILING PLANS FOR STATE, MUNICIPAL, AND PRIVATE PROJECTS.

AS CHAIRMAN OF THE N.C.A.R.B. COMMITTEE ON LICENSING HE HAS ASSISTED IN DRAFTING AND REDRAFTING LICENSING LAWS FOR SEVERAL STATES AND POSSESSIONS AND IS CURRENTLY DRAFTING A MODEL LICENSING LAW FOR THE ENTIRE COUNTRY. (SEE RECORD OF PUBLIC SERVICE.)

IN CARRYING OUT HIS WORK IN THIS AREA, THE NOMINEE HAS ADVANCED THE STATUS AND POSITION OF HIS PROFESSION AS A WHOLE.

5. AS A MEMBER OF THE JOINT BOARD OF ARCHITECTS AND ENGINEERS HE HAS SAT IN HEARINGS ON THE "McCAMY CASE" WHICH DEALS WITH THE LEGALITY OF PROFESSIONAL ENGINEERS PRACTICING ARCHITECTURE. HIS SPECIAL CONTRIBUTION IN THIS CASE, HAS BEEN TO ADVOCATE A CLARIFICATION OF THE DEFINITION OF ARCHITECTURE AS DISTINCT FROM ENGINEERING ON A NATIONAL LEVEL. THIS MAJOR CONTRIBUTION TO THE PROFESSION THROUGHOUT THE COUNTRY WAS UNANIMOUSLY ADOPTED BY THE CONVENTION OF THE N.C.A.R.B. IN PHILADELPHIA IN APRIL, 1961.

THE AMERICAN INSTITUTE OF ARCHITECTS ARCHIVES. For information or study purposes only. Not to be recycled, quoted, or published without written permission from the AIA Archives, 1735 New York Ave. NW, Washington, DC 20006

J. COI
IM
IN REVEN
VOL 221
MONT

- 6. THE NOMINEE HAS BEEN, SINCE ITS INCEPTION, A MEMBER OF A SPECIAL CHAPTER COMMITTEE FORMED TO CARRY ON DISCUSSIONS WITH THE SOCIETY OF PROFESSIONAL ENGINEERS TO EFFECT A SOLUTION TO ARCHITECT-ENGINEER JOINT RELATIONS AND LEGAL PROBLEMS.

- 7. THE NOMINEE, SERVING AS THE CHAIRMAN OF THE ARCHITECTURAL EDUCATION COMMITTEE FOR HUDSON COUNTY CHAPTER, NEW JERSEY SOCIETY OF ARCHITECTS HAS RENDERED A REAL SERVICE TO THE PROFESSION IN STARTING A STRONG PROGRAM OF GUIDANCE WORK WITH SECONDARY SCHOOL COUNSELORS FOR PROPER PRE-ARCHITECTURAL EDUCATION. HIS PROGRAM HAS BEEN SO SUCCESSFUL THAT IT HAS BEEN EXTENDED TO THE STATE LEVEL BY THE NEW JERSEY CHAPTER AND NEW JERSEY SOCIETY.

UNITED STATES PATENT OFFICE

2,233,901

SYSTEM OF ADAPTABLE ELEMENTS FOR TEMPORARY OR PERMANENT STRUC- TURAL FRAMING

John Scacchetti, Union City, N. J.

Application September 12, 1939, Serial No. 294,450

3 Claims. (Cl. 189—34)

There is an expanding need for an easily assembled and demountable frame for various structural purposes, in the building, manufacturing, trade and amusement fields. Such a frame, especially if for temporary use, should utilize standardized materials to a maximum degree, capable of comparatively simple replacement. So far as possible its parts should be interchangeable, for simplification and to give wide adaptability to location and function and should have a maximum of salvage or reuse value. For economy and to be practical its construction and the methods of assembly and demounting it should be easily understood by unskilled labor, inept in the use of complicated tools and equipment.

Weight is another factor to be considered. A trussed frame with secure joints has advantages in this respect over other forms of construction. Heretofore, braced frames of wood have been made far heavier than necessary, simply because of weakness of the joints; the excess material having been provided in order to secure adequate nailing area. The flexibility afforded by wood frames due to the easy cutting and nailing quality, is more than offset by its high salvage loss. The construction of a single swimming pool, even of moderate size, requires thousands of board feet of lumber for which there is no salvage value other than the possible resale to used material dealers of wood, which, although used but once, is affected by the adherence of cement particles, and is very apt to be warped and fit for nothing but kindling.

My invention therefore, is a form of framing which is adaptable to various uses, which may be quickly assembled and demounted, with minimum waste, and which may be employed in temporary or permanent structures, affording a strong, light work for supporting walls, forms, beams or other structural members. The principal element of my improved frame is a truss rod having at one end a face-toothed, preferably round, disk, so formed that any desired number of them may be fastened together at the disk end, and with the rods adjustable and firmly held to such angles to one another as may be useful in constructing a frame of any desired design. In constituting such a system, a group of the truss rods having a common center or radiating point, by reason of the assemblage upon a common axis of their disk shaped ends, are used either in a single group or united to one or more similar groups in the same manner, to form a frame of any desired shape and

extent. The truss rods may be of varying strength, weight and length and have means of adjusting their length, and fixtures of various kinds are employed for attaching the rods to structural members to be supported or stiffened, or for interconnecting the several rods of a frame to adapt it to the place and function desired. The invention contemplates such further cooperating detail members as will be described with reference to the accompanying drawings, and then more particularly pointed out in the claims.

In the drawings,

Fig. 1 is a side view, with parts removed, of a typical arrangement of my adaptable truss rods and associated elements, united to constitute a structural frame;

Fig. 2 is a perspective view of a clamping member;

Fig. 3 is a horizontal sectional view in the plane indicated by the line 3—3, Fig. 1, through the junction point of several truss rods and the clamp for connecting certain of them to the flange of a metallic structural member;

Fig. 4 is a similar sectional view of part of the same showing how the clamp is adapted to attachment to a wooden support;

Fig. 5 is a view similar to Fig. 3, but taken on the line 5—5, Fig. 1, showing a special form of anchoring member for a variable number of truss rods;

Fig. 6 is a sectional view, taken at right angles to Fig. 5;

Fig. 7 is a view in elevation illustrating a method of mounting the anchor member upon castors or dollies when the scaffold or other frame is to be movable;

Fig. 8 is a view of the same parts taken at right angles to Fig. 7;

Fig. 9 is a sectional view in a plane indicated by the line 9—9, Fig. 1, illustrating a form of coupling for varying the length of a truss rod;

Fig. 10 is a sectional view taken on the line 10—10, Figs. 1 and 11, illustrating a truss rod having its coupling member pivotally mounted upon its assembly disk;

Fig. 11 is a view in elevation, partly in section, taken in a direction at right angles to Fig. 10;

Fig. 12 is a side view showing another way of pivotally connecting the housing member of a truss rod coupling to its centering or axis disk;

Fig. 13 is a sectional view illustrating the method of connecting two truss rods for resisting transverse strains, the plane of section being indicated by the line 13—13, Fig. 1;

Fig. 14 is a side view of the same;

Fig. 15 shows in perspective a frame illustrating my invention in both standing and suspended types, applied to the supporting or bracing of the forms for pouring of a cement wall or otherwise as a shoring or bracing frame for centering or other structural use;

Fig. 16 is a detail sectional view taken on the line 16-16, Fig. 15;

Fig. 17 is a similar view illustrating the use of wooden instead of metal posts or studding; and Figs. 18 to 23 inclusive illustrate in perspective useful applications of my invention to temporary, semipermanent or permanent frames for various purposes.

A frame constructed in accordance with my invention may be two or three-dimensional. In Fig. 15 two three-dimensional forms are shown, one, a standing frame A on the hither side of the wall or mold form 25 and supported on the floor girders 26, and another, beyond the wall or mold form, a suspended frame B carried by overhead girder 27. However, in these, as in other forms shown, the three-dimensional frame may be regarded as made up, wholly or partly, of a plurality of two-dimensional frames, such as that exhibited in Fig. 1, with supplemental devices when necessary for solidly supporting it and supporting a form or other structural element from it and for bracing the several two-dimensional frames.

Fig. 1 may be referred to, to obtain an idea of the elements going into a frame such as shown in Fig. 15 and others which will be indicated. The unit of construction is a truss rod which has, at one end, means for coupling it at any desired angle to the like coupling member of another truss, and at the other end means for connecting it to another truss member or to a fixed support, the resulting frame when assembled comprising a series of unions or nodal points whereat a plurality of truss bars unite so as to radiate therefrom at different angles and the radiating members serve to connect the unions with various supporting or extension devices. In Fig. 1, I have shown four truss rods 28, 29, 30, 31, preferably of steel of such strength and stiffness as required for the individual job, varying for example, with the weight to be supported and the height to which the frame is to extend. The rods radiate from a common union 32. At this union, disk shaped ends 33 of the truss rods held together by bolt and nut 34, enable the setting of the several truss rods at angles which will enable them to perform different functions. The rods 28, 29 and 30 for example are so positional that their right hand ends are in a vertical line adjacent to the structural member 35 which they are to support, or by which they are to be supported, while the fourth radial truss rod 31 is connected to an anchoring member 36 remote from the member 35.

In all of these the same method of union is employed. That is, like face-toothed disks, one on each truss member, are brought in contact and united by a bolt at their common axis, and this, whether the union be for uniting a number of truss rods to each other or for uniting one or more truss rods to a structural member. The disks 33 are toothed on both faces at 33a so as to make assembly easy without regard to the order of arrangement of the trusses on the union. The teeth are radial to the common axis of the disks, so that the trusses may be adjusted to the angles required by the individual struc-

ture and the teeth take up the torsional effect of the trusses about the union axis, the bolt and nut serving only to hold the disks together. As shown throughout the figures, the surfaces of two disks when laid close together have intimate contact throughout their toothed faces. To assure that each side of every disk will be operable with each side of every other disk, the faces are, as shown particularly in Fig. 2, formed as exact counterparts—each ridge of each disk being an exact counterpart of every groove on both sides of every disk. Thus any number of truss disks may be assembled (Fig. 15 shows from two to six or more) on one connecting bolt—limited only by the length of the bolt. This result cannot be obtained by pressing or stamping a toothed rosette from the body of a truss member, the two sides of such a rosette being necessarily different by reason of the interposition of the thickness of the metal of the bar in which the rosette is stamped. The surfaces of the engaging radial teeth are entire, presenting a continuous frictional surface to the adjacent surface of a disk nesting therewith, so as to make, when bolted together, a substantial, solid structure, well fitted for the strains which a practical scaffolding is called upon to withstand without turning or shifting of one element upon the other, which would endanger the value of the frame as a support for workmen and material.

The truss rod 28 is made up of a disk carrying arm 37 at each end and means extensibly connecting these members, comprising, in this instance (see Fig. 9), interiorly screw threaded socket members 38 in which is seated an exteriorly screw threaded split nut 39 which may be turned by its lugs 40 (see Fig. 1) with a spanner wrench. A chamber 41 within the nut will take, when the split nut is separated, the cap 42 of a pipe or bar 43 whose length is chosen according to the length of the truss rod desired. Smaller adjustments of length can be made by screwing or unscrewing the nut 39.

The truss rod 29 is shown in section in Fig. 3, and the clamp member thereof in Fig. 2. It has a pipe or bar 43 of variable length screwed in cap ends 44 of a disk-ended arm 37 identical with those of rod 28 and ending in face-toothed disks 33 one of which forms part of the union 32 and the other has similar engagement with the toothed disks 33 extending radially from the edge of which are the arms of clamp members 45 of U-shaped cross section, and so having channels 46 engaging the vertical web or flange 47 of the structural post or stud 35, the clamp arm 45, its clutch disk 33 and its means of attachment to the structural member 35 being alike for all the truss rods 28, 29 and 30. Two clamp members 45 engage the opposite sides of the post web or flange and are held by bolts and nuts 49 at any desired position. The inside of the channel 46 may for, say one-third of its depth, be filled with a replaceable lining of soft metal 48 which will tend to provide greater friction when the bolts are drawn tight. For permanent work or where fixed dimensions are predetermined, connection may be made rigid by bolting, welding, riveting, etc. The right hand face of the clamps are widened by the flange 50 to enable its use when a wooden post or stud 35a is employed, in which case the clamp may be attached to the beam by screws as shown in Fig. 4. The channels 46 are in such an arrangement freed from restraint of the flange 47 and permit enough yielding action to allow the toothed disk to be set up tight.

Truss rods,
truss rod 29 f
member 35 o
off from it a
5 of the figures
14 for provid
of truss rod
trussing. Th
the truss 30
10 or clutch des
character 5
bers, pivoted
upon separat
member com
15 the pipe or
provided wit
rotation one
end engages
also slipped
20 56 screws on
internal scre
ing the nut
loosened, th
lease the pi
lar at any d
lar 59 by p
collar 59 wit
pipe or rod
nected by it
30 at a point r
60 in Fig. 18
of the regul
adjustability
51 to any
35 parent. A
number of
55, holds th
crossing tr
and held at
40 Another
transverse
and 11, wh
vided with
37b of a t
45 other truss
ready expl
Another
shown in
an eye 63
50 ing from a
ple, from
that show
In Fig.
truss rod,
55 a turnbuc
is shown i
truss rod
member a
In Fig.
60 which ma
dation for
against th
by bolts 4
the found
65 cement, e
it securel
Fig. 6, mc
a steel I-
At Fig.
70 tion capa
disks bet
the side p
71 adapt
plates.
75 Figs. 7

Truss rods 28 and 30 have the same means as truss rod 29 for connecting them to the structural member 35 or 35a. Truss rod 30 has also taken off from it a member 51 illustrated in a number of the figures and shown in detail in Figs. 13 and 14 for providing a truss in a plane normal to that of truss rods 28-31, for lateral bracing or trussing. The main longitudinal member 43 of the truss 30 passes through the spring ring clamp or clutch designated in general by the reference character 51, comprising two like clutch members, pivoted together and mounted adjustably upon separate truss bars 43 and 43a. Each clutch member comprises a screw ring 52 slipped upon the pipe or rod 43 or 43a and shouldered and provided with a hole 53 to receive and hold from rotation one end of a spiral spring 54 whose other end engages a groove and similar hole in nut 55 also slipped on the pipe 43. An abutment ring 56 screws onto ring 52 and the nut 55 engages an internal screw thread in a collar 59. By adjusting the nut 55 the spring 54 is tightened or loosened, thus causing it at will to clutch or release the pipe 43a and optionally attach the collar 59 at any desired point. Swivelled upon the collar 59 by pivot bolt 57 is a collar 58 similar to collar 59 with like clutch arrangement for a cross pipe or rod 43a which serves as a cross truss connected by its toothed disk to form part of a union at a point remote from truss 30. Or, as shown at 60 in Fig. 18, such a cross truss may connect two of the regular unit trusses. Here the value of the adjustability of the two sections of the coupling 51 to any angular relation desired becomes apparent. A lock pin 60a or 61a entering one of a number of holes 60b in the collar 58 or 59 and nut 55, holds the spring clamp in set position. The crossing truss rods 43 and 43a may thus be set and held at any point where they cross.

Another method of connecting members by a transverse truss rod is shown at 61, Figs. 1, 10, and 11, wherein the disk 33 has its arm 37a provided with a pivot pin 62 on which turns the arm 37b of a truss rod which may be connected to other truss rods or to a structural member as already explained.

Another way of connecting to a cross truss is shown in Fig. 12 wherein the disk arm 37c has an eye 63 which engages a pivot lug 64 projecting from a member of a truss rod, as for example, from the socket member 38 of like form to that shown as part of truss rod 28 in Fig. 1.

In Fig. 1, I have also shown at 31 a form of truss rod, the length of which is adjusted by a turnbuckle 65 and a similar adjusting means is shown for the horizontal truss rod 66. Such truss rod connections are sufficient where the member acts particularly as a tension member.

In Fig. 1, I have shown at 67, 68 two I-beams which may serve as foundation or part of foundation for the frame. Side plates 69 are held against the two sides of the clamp plates 45a by bolts 49a. Eccentric cam latch 70 fastened to the foundation which may be wooden plank or cement, engaging the flanges of the I-beam, hold it securely. This construction is also shown in Fig. 6, modified to suit a wooden joist instead of a steel I-beam.

At Fig. 5 means of mounting upon a foundation capable of receiving any number of truss rod disks between the clamp plates is shown. Here the side plates 45 are connected by a grill or comb 71 adapted to enter the channels of the clamp plates.

Figs. 7 and 8 exhibit the mounting of the foun-

ation upon dollies 72, to enable the foundation and frame supported thereby, to be moved about as desired.

The invention is capable of a great many applications, a few of which are exhibited in the drawings, Fig. 18 showing a permanent or demountable moving or stationary scaffolding, staging, platforming, etc.; Fig. 19, temporary or permanent frames for seating; Fig. 20 a bracing and supporting frame for fences, barricades, boardings, etc.; Fig. 21 protection bridges over walks or drives, temporary sheds, hoist shafts, rubbish or material discharge or delivery chutes; Fig. 22 standardized housing framing, adjustable for height, width or length and for varying window, door and site conditions, frames for temporary or permanent sheds, exhibition booths, shelters, and framing for floor or pitched or flat roof forms; and Fig. 23 temporary or permanent bridges, cat walks, etc. The forms selected being only illustrative of the numerous fields in which the invention will be found useful.

The use of this frame for these or similar constructions of walls, floors, or roofs, together with the standardized form of metal, or the alternate form of wood or other nailable material, would afford the fullest measure of salvage, as none of the joints are disturbed.

The structural quality of the frame also permits its use as a suspended form where clearances must be maintained due to traffic conditions, or where obstructions prevent the use of other types of installation.

Shoring or bracing of walls or banks may be easily accomplished, as the flexibility of the design permits adjustment to any height or pitch from any level.

Platforms used in maintenance work, or by trades where operation from height is necessary may be constructed with this frame and arranged for the necessary clearances below for the passage of traffic or handling of materials.

Temporary structures for seasonal use, such as, gang planks from boat landings or floats, may be built up as required and added to if greater length is desired without waste. The easy demounting permits storing in a minimum area.

Temporary cat walks for spanning construction work are also easily constructed and taken down with complete salvage of all parts.

Military maneuvers involving the use of small, portable, light bridges, require equipment which can be quickly assembled and taken down for rapid transportation.

It is also easily adaptable for use as a foundation for temporary seating in areas of multiple purpose where rapid changes of function are required.

Temporary fencing, canopies, and frames, for sheds, buildings, etc., and billboards used in advertising are other fields in which the frame could be utilized to advantage.

For whatever temporary purpose it is utilized, complete demounting is unnecessary. Loosening at the joints is sufficient to bring the parts in a parallel line.

With slight modification of its structural details as a consequence of reduction in scale the parts may be very easily adapted as an educational toy or game.

From the foregoing description of its various embodiments selected for illustration, it will be seen that the present invention contemplates certain novel features in the construction of prefabricated framing members, a plurality of which,

approximately identical in form, may be employed in the building of a two dimensional frame, such for instance as a framing for a scaffold, wall or the like; or a plurality of such frames interconnected; and which said framing members comprise as their essential identifying characteristics, truss rods carrying at their ends coupling discs having flat assembly faces adapting several of such discs to be stacked and held together about an axis of assembly with their several truss rods radiating from said axis, in various directions in a plane of load distribution, or in some instances deflected from said plane as in serving to connect two such frame structures, or as bracing connections therefor; some or all of the truss rods so assembled being composed of at least two strutting members substantially coinciding with the longitudinal axis and carrying the coupling discs of said rods; the strutting members of the truss rods being relatively rotatable about said longitudinal axis to enable the coupling disc or discs of each truss rod to present their stacking faces in parallelism with faces of other discs which they meet in the assembly; means being interposed between the strutting members of each truss rod, such as screw threaded connections, whereby said strutting members may be forcibly moved relatively to each other and the length of the truss rod may be changed; and this changing of length may be attained without rotation of the stacked discs and therefore accomplished after assembly is completed and with the effect of placing each framing member under tension or compression as may be desired in stiffening the frame, distributing load throughout the frame, and justifying the frame structure as may be desired. The designation "truss rod" herein employed refers to a framing member whether it is under tension or compression.

It will also be seen that the invention further contemplates the construction of the assembly faces of the discs with appropriate formation such as radial ribs and grooves which will permit two discs to be placed together at any desired relative angle of rotation about the assembly axis, as for instance in determining the radial positions of the truss rods in the plane of load distribution; also the introduction of flexing joints between certain of the truss rods and their coupling discs in order to permit desired deflection of such truss rods from the plane of load distribution and giving to a bracing or frame connecting truss rod an enlarged range of movement in attaining definite points of anchorage; and particularly permitting shifting of the plane of radius action offered by such a joint to any one of a number of planes determined by the relative rotation of the assembly disc about the stacking axis.

I claim:

1. A structure having truss bars united to form a frame and means for attaching said frame to a foundation or other structure, comprising flanged clamp-plates, side-plates having grills or combs to engage the flanges of the clamp-plates, and

means for holding the side-plates against the clamp-plates with the flanges of the clamp-plates in engagement with the grills or combs of the side-plates.

2. In a scaffold or like frame structure, a plurality of framing members comprising truss rods carrying at their ends coupling discs constructed with assembly faces that adapt said discs to be stacked and clamped together in superposed relation at an assembly center in a plane of load distribution of the frame and with the truss rods radiating from their respective stacked discs at said center in selected positions in said plane and in directions appropriate to the frame being formed; each truss rod being composed of at least two strutting members substantially coinciding with the longitudinal axis of the truss rod; the strutting members of each truss rod being relatively rotatable about said longitudinal axis and thereby enabling coupling discs at the ends of the rod to present themselves in parallelism with faces of other discs which they meet in the stack; means being interposed between the strutting members of each truss rod for forcibly imparting relative longitudinal movement to said strutting members and thereby changing the length of the truss rod; and the coupling discs on the strutting members of a truss rod being free to remain in stacked and clamped position during such length adjustment.

3. In a scaffold or like frame structure, a plurality of framing members comprising truss rods carrying at their ends, coupling discs constructed with assembly faces that adapt said discs to be stacked and clamped together in superposed relation at an assembly center in a plane of load distribution of the frame and with the truss rods radiating from their respective stacked discs at said center in selected positions in said plane and in directions appropriate to the frame being formed; at least one of said truss rods having hinging connection with its disc in the stack that permits deflection of such hinged truss rod at a substantial angle to said plane of distribution and leaves it free to swing in a plane perpendicular to said plane in reaching a point of anchorage outside of said plane; each truss rod being composed of at least two strutting members substantially coinciding with the longitudinal axis of the truss rod; the strutting members of each truss rod being relatively rotatable about said longitudinal axis and thereby enabling coupling discs at the ends of the rod to present themselves in parallelism with faces of other discs which they meet in the stack; rotational means being interposed between the strutting members of each truss rod for forcibly imparting relative longitudinal movement to said strutting members and thereby changing the length of the truss rod; and the coupling discs on the strutting members of a truss rod being free from partaking of rotation of the length adjusting means and thereby permitting the length adjustment to take place after the coupling discs are assembled.

JOHN SCACCHETTI.

March 4, 1941.

J. SCACCHETTI
SYSTEM OF ADAPTABLE ELEMENTS FOR TEMPORARY OR
PERMANENT STRUCTURAL FRAMING
Filed Sept. 12, 1939

2,233,901

6 Sheets-Sheet 1

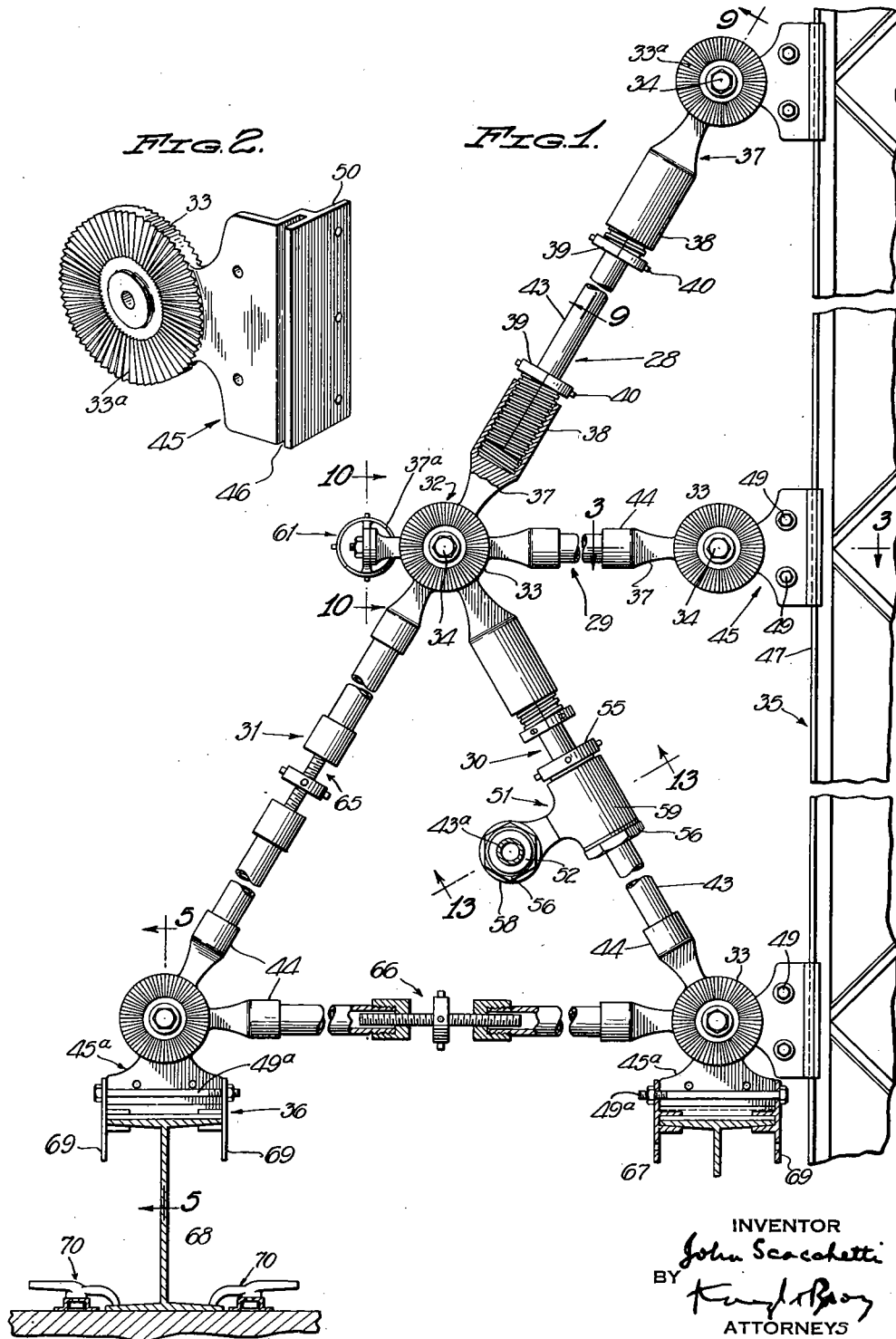

THE AMERICAN INSTITUTE OF ARCHITECTS ARCHIVES For information or study purposes only. Not to be recycled, quoted, or published without written permission from the AIA Archives, 1735 New York Ave. NW, Washington, DC 20006

INVENTOR
John Scacchetti
BY *Kemp & Boy*
ATTORNEYS

March 4, 1941.

J. SCACCHETTI
SYSTEM OF ADAPTABLE ELEMENTS FOR TEMPORARY OR
PERMANENT STRUCTURAL FRAMING
Filed Sept. 12, 1939

2,233,901

6 Sheets-Sheet 2

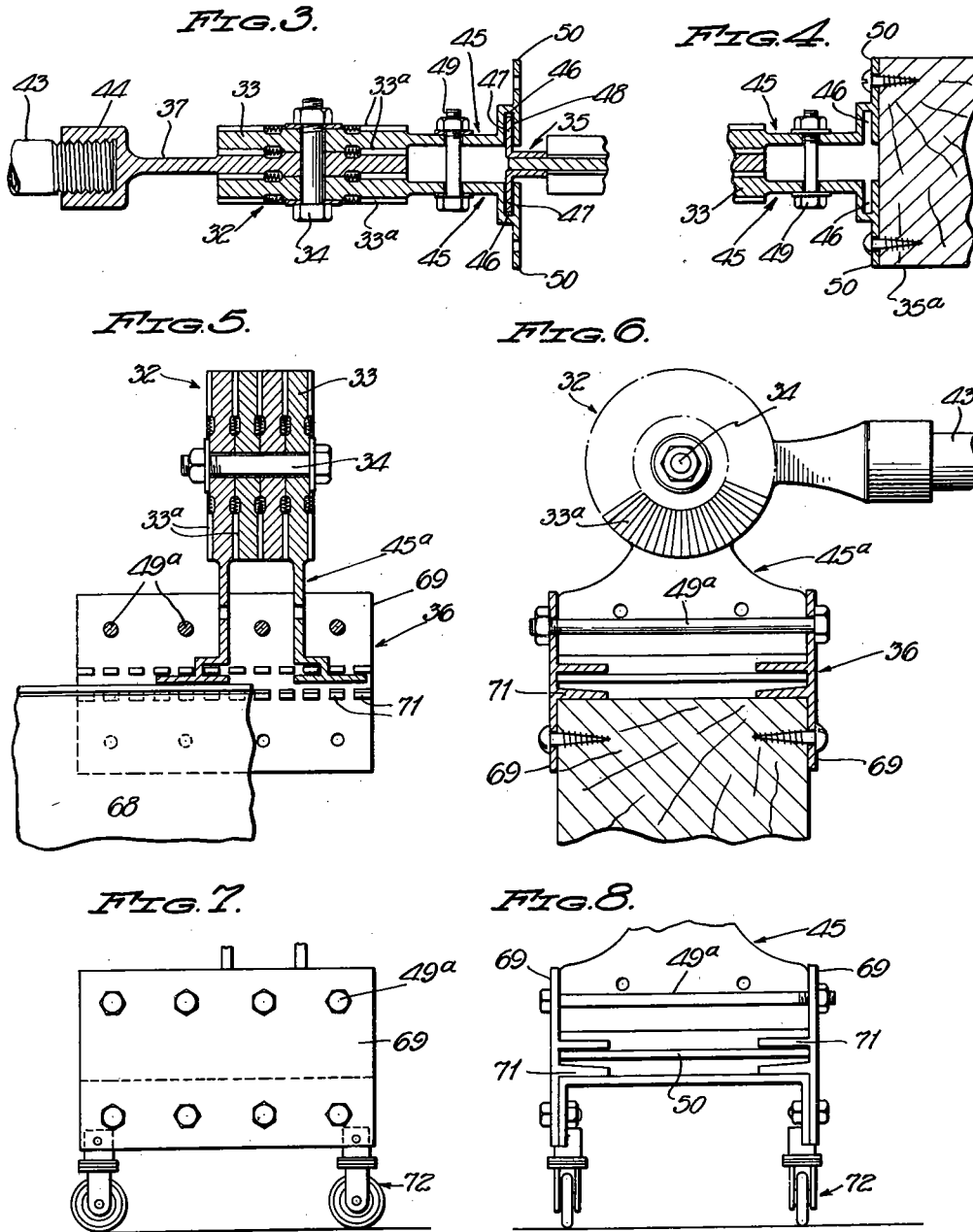

THE AMERICAN INSTITUTE OF ARCHITECTS ARCHIVES For information or study purposes only. Not to be recycled, quoted, or published without written permission from the AIA Archives, 1735 New York Ave. NW, Washington, DC 20006

INVENTOR
John Scacchetti
BY *King & Boy*
ATTORNEYS

March 4, 1941.

J. SCACCHETTI
SYSTEM OF ADAPTABLE ELEMENTS FOR TEMPORARY OR
PERMANENT STRUCTURAL FRAMING
Filed Sept. 12, 1939

2,233,901

6 Sheets-Sheet 3

FIG. 9.

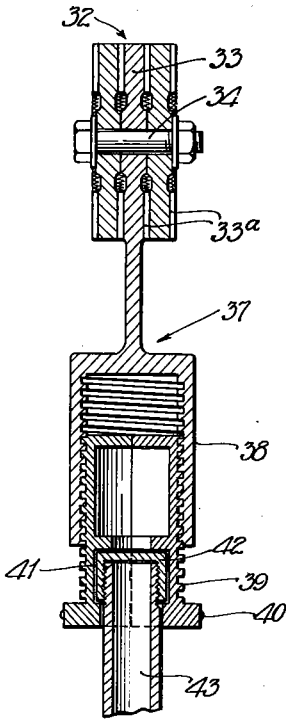

FIG. 10.

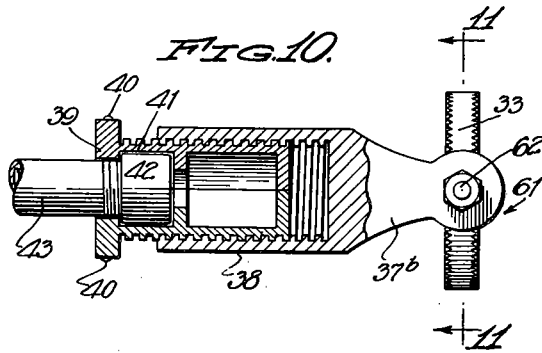

FIG. 11.

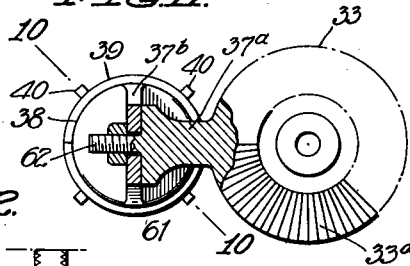

FIG. 12.

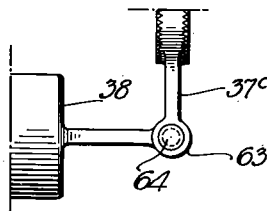

FIG. 13.

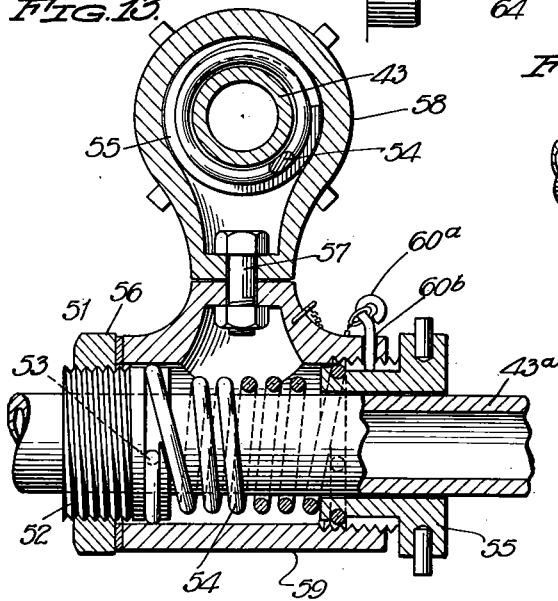
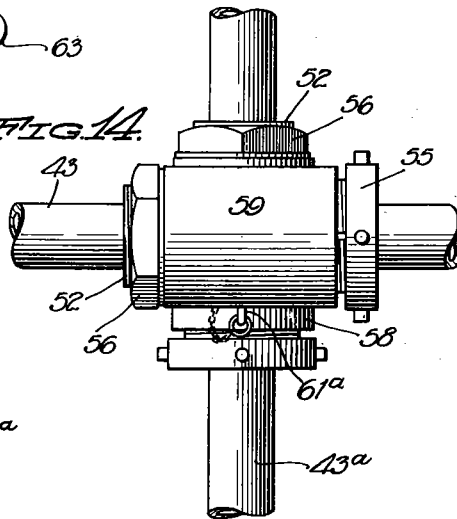

FIG. 14.



INVENTOR
John Scacchetti
BY King & Brown
ATTORNEYS

March 4, 1941.

J. SCACCHETTI
SYSTEM OF ADAPTABLE ELEMENTS FOR TEMPORARY OR
PERMANENT STRUCTURAL FRAMING
Filed Sept. 12, 1939

2,233,901

6 Sheets-Sheet 5

FIG. 18.

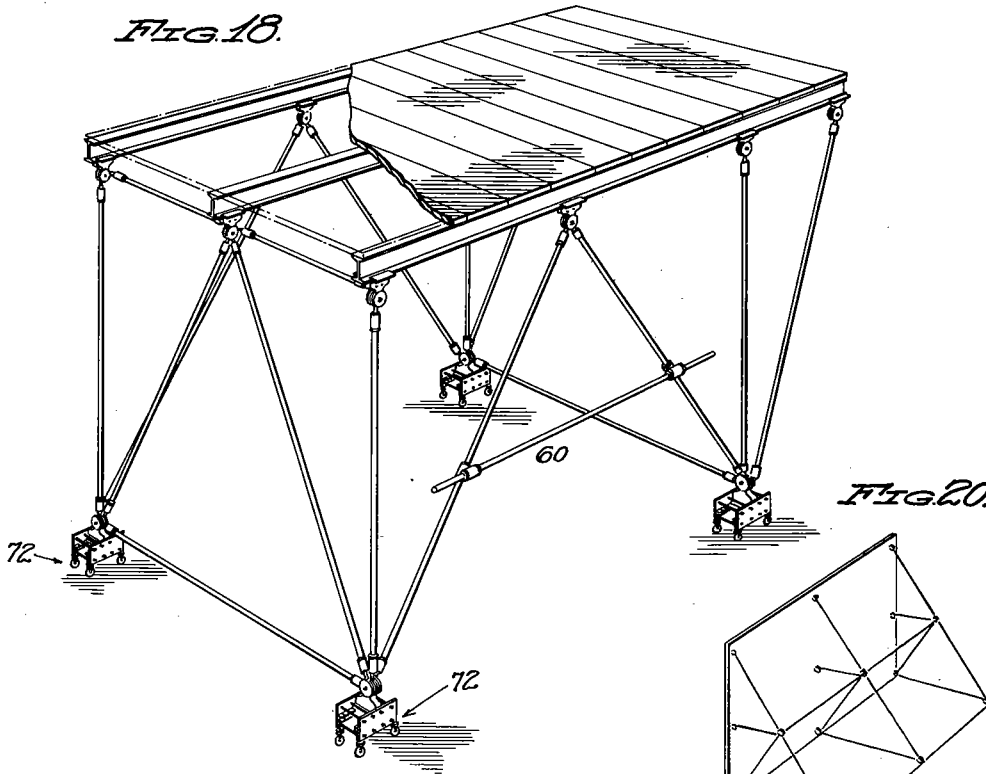
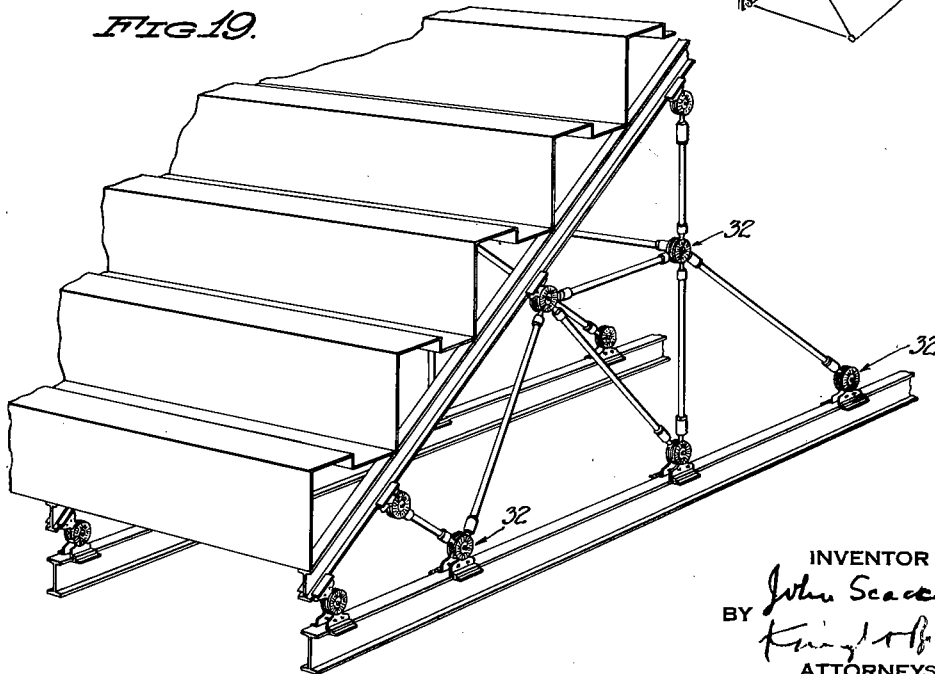

FIG. 19.



INVENTOR
BY *John Scacchetti*
Kingston
ATTORNEYS

March 4, 1941.

J. SCACCHETTI
SYSTEM OF ADAPTABLE ELEMENTS FOR TEMPORARY OR
PERMANENT STRUCTURAL FRAMING
Filed Sept. 12, 1939

2,233,901

6 Sheets-Sheet 6

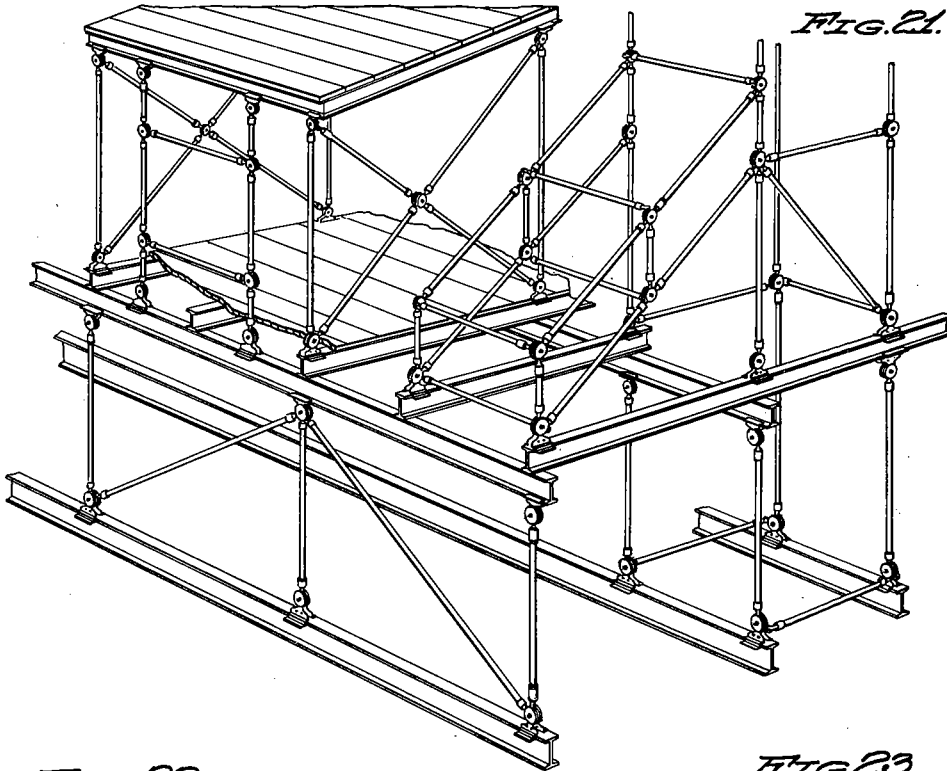

FIG. 21.

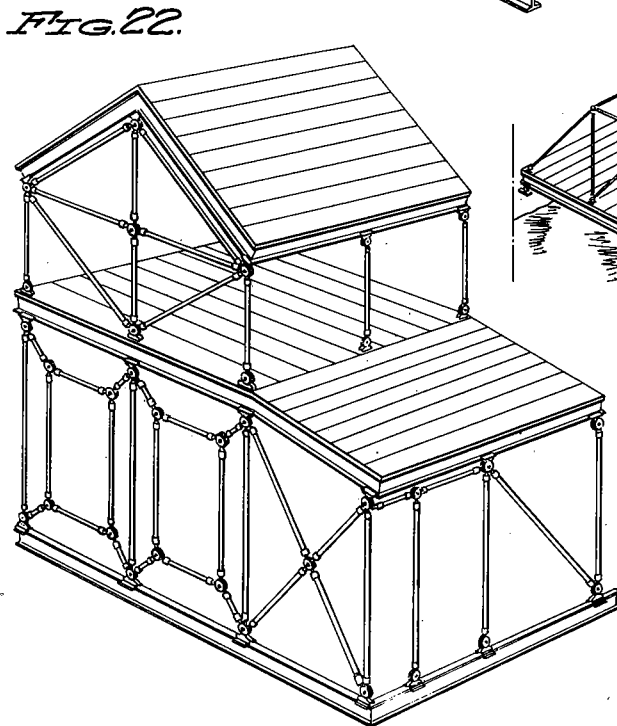

FIG. 22.

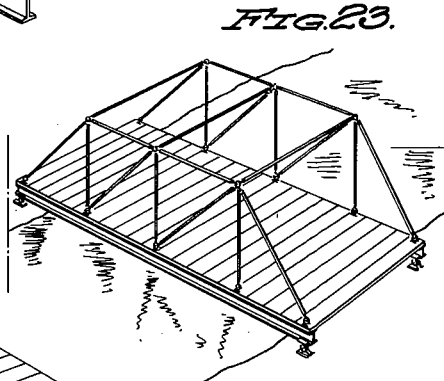

FIG. 23.

INVENTOR
John Scacchetti
 BY *Kemp & Co.*
 ATTORNEYS

THE AMERICAN INSTITUTE OF ARCHITECTS ARCHIVES For information or study purposes only. Not to be recopied,
 quoted, or published without written permission from the AIA Archives, 1735 New York Ave. NW, Washington, DC 20006

There is assembled a structural framing, truss frame, especially utilize standard gree, capacity. So interchang
 10 wide adapt should have value. For construction mounting
 15 skilled labor tools and Weight trussed fra in this res
 20 Heretofore made far cause of w terial have adequate
 25 by wood fr ing quality vage loss. ming pool sands of t
 30 is no salva to used ma used but cement pa and fit for
 35 My inven which is a be quickly mum waste porary or
 40 strong, lig forms, bear principal truss rod h erably rou
 45 the disk ef firmly hel may be us desired de
 50 a group of ter or radi blage upon ends, are to one or
 55 ner, to for



THE AMERICAN INSTITUTE OF ARCHITECTS

DECLARATION OF AUTHORSHIP

THE following certification must accompany the photographic exhibit. It may be signed by anyone in possession of full knowledge concerning the development of the design. This might be the Chapter President, a member of the Executive Committee of the Chapter, a partner of the nominee, or even the nominee himself. If the various examples were developed under different conditions respecting authorship, the various statements below should be keyed to the proper exhibits.

The accompanying photographs show examples of work with which the nominee's connection was as follows:

- The nominee was solely responsible for the design.
- The nominee was largely responsible for the design.
- The design was under the direction of the nominee.
- The nominee's firm executed the design.

Signed

John Sarchetti

Title

Architect Dec. 21-1961

DEC 29 1961

March 12, 1962

Mr. Adolph R. Scrimanti, President
New Jersey Chapter, A.I.A.
205 West Main Street
Somerville, New Jersey

Dear Mr. Scrimanti:

The Jury of Fellows has requested me to advise you of the following action it has taken on the nominations before it of corporate members of your Chapter who were considered for advancement to Fellowship:

Referred to Meeting of The Jury in 1963:

Daniel Arthur Hopper, Jr.
John Lebatut
John Scocchetti

Any further material that you wish to submit in connection with these nominations should be received by The Jury of Fellows at The Octagon by November 15, 1962.

Nominations Before The Jury at Three Meetings Without Favorable Action:

Robert Johnstone Lewis Cadion
Lawrence Christian Licht
Arthur Rigolo

We regret to inform you that these members have not been honored with Fellowships by The Jury of Fellows. The exhibits submitted in support of their nominations are being returned to you under separate cover.

The Jury has asked me to inform you that, in their deliberations during the past three years, these proposals have been considered among the several hundred with which they have had to compare them as to their qualifications.

The Rules of Procedure of the By-Laws, of The Institute permit the re-submission of new nominations after the lapse of one year following this action.

The Jury suggests that if you take this course, you make a more adequate presentation which will tell clearly what you feel are sufficient grounds for different action.

October 16, 1962

Mr. James A. Swackhamer, AIA, Secretary
New Jersey Chapter, AIA
205 W. Main Street
Somerville, New Jersey

Dear Mr. Swackhamer:

On behalf of The Jury of Fellows, this will acknowledge receipt of additional material regarding the Nomination for Fellowship of Mr. John Scacchetti, AIA., which will be supplemented to his nomination and presented to The Jury when it is under consideration.

Sincerely yours,

Maureen Marx, Assistant Secretary
The Jury of Fellows

ADDITIONAL MATERIAL SUBMITTED ON

JOHN SCACCHETTI, AIA

New Jersey Chapter

Nominee for Fellowship

For Review by the

JURY OF FELLOWS

1. Being An Architect Is Not Easy.
2. Administering the Licensing Law. Part 1.
3. Administering the Licensing Law. Part 2.

Submitted by:
James A. Swackhamer, AIA
New Jersey Chapter

August 27, 1962

The following article, "Being An Architect Is Not Easy",
was written by John Scacchetti, AIA, and published in
the 1962 issue of the Convention Handbook of the New
Jersey Chapter, The American Institute of Architects
and the New Jersey Society of Architects.

Visitors to the offices of the N. J. State Board of Architects will be mystified at the feverish activity of staff on the telephone following the semi-annual examinations. The call from participants, start within few days and continue with diminishing vigor for the weeks, some pleading, some impatient, but all with eagerness to learn the result of their effort to qualify for a license to practice architecture. They are justifiably anxious, although premature, for architecture is most important to them and this time is the high point of their careers.

Counting the three years minimum of necessary experience the average candidate, after schooling, has spent under the discipline of the profession for almost half of his entire life. It is understandable then that he would be anxious about his future.

During the interview granted the successful candidate before the Board, the questioning will explore his attitudes as well as the weaknesses disclosed in his presentation. Some measure of advice will be offered which may, because of the conditions, have more impact on one given under less auspicious circumstances.

From this moment on, the Board and the successful candidate may never again meet. He is now an architect, independent, free to practice and presumably content to secure commissions for projects of any magnitude or cost. The level of success attained in the conduct of his profession will be only a slight deterrent in the method he chooses to pursue, not nearly as much of an influence as the behavior of his fellow practitioners to whom he will look for guidance in view of their longer experience.

The disappointments with which the established practitioner is aware, loom much larger in the mind of the new architect and especially so if there is evidence, never slight, that they are brought about by marginal practices of others who supposedly subscribe to the same professional code. Deviation from accepted standards as an effective weapon of attack and used as inducement to secure commissions may well be the course chosen by the new licensee since the behavior of others, being apparent, must surely be condoned.

The unfortunate result is that of impressing further on the mind of the layman the false image of a profession with standards varying with expediency, and satisfactory performance emerging as a matter of luck and capability.

In the struggle for recognition and acceptance strong efforts will be made to attain a maximum level of proficiency in specific types of structures, the means and ends of which are predetermined by archaic regulations and mediocre precedents. Yet, because of the varied character and quality of the project, adequate performance and profit are insured and with not any more effort than that required to secure a number on a mechanical computer. This is contrary to the

Being an Architect Is Not Easy

JOHN SCACCHETTI, A.I.A.

years of study spent in acquiring the knowledge so conveniently assembled for him and absorbed with not inconsiderable effort. The admonitions of the Board in stressing the need for the development of the complete architect, first with its examination and later in the interview, are lost.

The trend, especially by agencies, to emphasize the need to engage a practitioner completely and thoroughly an expert in a particular classification of structure is to be deplored. It is less important that the architect know the dimension of a book to fit into a case, the height of a plumbing fixture or the number of risers permitted in a staircase, than to know his function is precisely the same whether he is commissioned to do a hotel or a hovel.

In the course of his practice, the architect will acquire many details of information of varying importance, but unless he is alert to the need for periodic review of his mental storehouse he will find his work reflecting obsolete ideas since discarded in the interest of better results and performance.

To demand that the architect be familiar with all the technicalities of a specific structure as a condition for securing a commission is to compel him to abdicate from his professional status to that of a technician working in competition with non-professional specialists whose entire interest is centered on the production or distribution of fixtures and equipment.

The profession needs the new practitioners with their enthusiasm and ideas. In turn, the established architect must, by his attitude and professional behavior, establish a standard which will inspire and assist the young architect in his early years of trial.

The increasing respect and recognition for the profession will be the reward which can be shared with pride by all those who have chosen to be counted as architects.

The following article, "Administering the Licensing Law"
was written by John Scacchetti, AIA, and published in two
installments in the June and August (1962) issues of the
AIA Journal.



A. Reinhold Melander, President, Duluth, Minn; Chandler C. Cohagen, 1st Vice President, Billings, Mont; Paul W. Drake, 2d Vice President, Summit, NJ; A. John Brenner, Secretary, Phoenix, Ariz; C. J. Paderewski, San Diego; Earl L. Mathes, New Orleans; John E. Ramsay, Salisbury, NC; George F. Schatz, Cincinnati, Directors; Walter F. Martens, Past President, Charleston, WVa

Administering the Licensing Law

by John Scacchetti, AIA

The author is a former president of AIA's New Jersey Chapter and of the New Jersey State Board of Architects. For the past three years, he has been Chairman of NCARB's Licensing Committee. He is now working on a draft of a model licensing law for the entire US

► Licensing laws governing the practice of architecture have been in effect in all fifty states, Canal Zone, Puerto Rico and The District of Columbia for sufficient time for every architect to be aware of their existence.

Architects practicing legally in their own states should be aware also that similar regulations in other states require that a license be secured before engaging in any work if disciplinary action for violation of the statutes is to be avoided.

Time, too, is as important a factor as knowledge of the need for applying for a license.

Reciprocal licensing, whether applied for by the individual or through the National Council of Architectural Registration Boards, is neither automatic nor instantaneous. Qualifications considered sufficient for acceptance in one state cannot be assumed to be acceptable in all others. (This would be true even though all states operated under a uniform model law.)

An applicant, anxious to secure registration immediately to satisfy the demands of a project which has suddenly come to life, will in all probability find that the State Boards do not meet with such frequency as to coincide with his time schedule.

Even though the board may conveniently be in session to consider the applicant's plea, it is often further delayed by the tardy responses of the endorsers named in the application. Confronted

with seemingly unwarranted delays, an impatient applicant may harbor the suspicion that the board's inaction is motivated by a desire to restrict the number of licensees, or that bureaucratic conformity has caused his urgent pleas for immediate relief to fall on deaf ears. It would be unusual for the action to be considered as a necessary safeguard to protect the public, as well as to ensure that only the properly qualified will be granted licenses to practice.

The need for a model law is far less than that architects become familiar with the statutes now in effect.

Architects who are conscious of the need to study all laws and regulations concerning design and construction are curiously uninformed on those governing their own practice, often falling prey to their own weakness in this regard.

This deficiency is revealed not only when they apply for registration in other States, but is also apparent in the conduct of their practice in their home State.

When they are charged with a violation, a plea of ignorance is their sole defense.

The most casual practitioner, on securing a commission, will immediately check on all the laws governing the design and construction of a project, yet will carelessly delay taking steps to acquire the license which is essential before he can legally proceed with the work.

Complaints of an architect's activity before licensing as to require board action are often initiated by someone whose interests are neither in sympathy with the architect nor his intentions, and usually succeed in delaying processing of his application until the violation is cleared.

The discretionary powers of the board are limited and penalties for violations must be assessed in accordance with their statute. Through the years the New Jersey State Board has found, in rare circumstances, that sufficient reasons can

be advanced to temper the decision and allow a violation to be dismissed with censure, together with a warning that more drastic action will follow if the situation is not remedied.

It should be noted that violations and penalties become permanent records which are available to the NCARB and to any State Board seeking information on an applicant.

A board exists for the purpose of administering without prejudice a mandatory statute applicable equally to residents or out-of-state licensees.

Consciousness of responsibility and accomplishment in his profession are prerequisites to an architect's service on a board and are utilized in the discharge of his duty, which is to uphold the rights of the public and to protect their health, welfare and safety.

A board cannot, as a rule, judge morals or ethics, but must confine its decisions to the law which penalties are provided for offenses which affect the well-being of the people, rather than to satisfy the wrongs presumably committed against the aggrieved complainant.

Practice by unlicensed individuals under circumstances permitted by exception clauses written in most statutes produce some rather startling evidence at hearings, yet the board has little latitude either to exact penalties or otherwise punish offenders.

Flagrant abuses where fraud is more than reasonably evident are referred by the New Jersey Board to the Attorney General's office for action under other statutes beyond the limits of the board's authority.

On occasion, however, it is possible to assess penalties against violators for illegal practice.

Multi-unit residence structures on which permits are secured from drawings, with an affidavit of authorship attesting that occupancy will be for individual or members of his immediate family, constitute one of the knotty problems which confront the New Jersey Board and for which there is no definite rule to govern its procedure.

Variants of this are found in combination businesses and residence buildings as well as industrial structures, in fact in any building where the individual is willing to swear that he will occupy the premises.

The use of stock or standard drawings can be more easily detected and discouraged by requiring the signature of a licensed architect to be applied to the original drawing so that it will appear on all reproductions. It should also be required that the seal be impressed on all reproductions which are to be used for filing or contract purposes, rather than a rubber stamp applied on originals.

This regulation in New Jersey has succeeded in eliminating the indiscriminate circulation of standard drawings which heretofore had been available for adapting to any location and validated merely by obtaining the seal and signature of any architect willing to assume the responsibility for a trifling fee.

Press releases through the state agency listing violators and assessed penalties have not increased the Board's popularity in some areas, but complaints have been more than balanced by the pleased response of others whose interests are more directly affected.

Fortunately, not all the board's efforts are directed toward violations or individuals challenging its powers. An equally important activity is the preparation of examinations for prospective new licensees.



John Scacchetti, AIA

Applicants registering for the semi-annual examinations in New Jersey are carefully screened to be sure that scholastic and experience requirements are fully met. While the number of graduates from accredited schools is increasing annually, the problem of evaluating candidates with sufficient credits obtained from non-accredited or foreign schools requires close study by the board. In these latter cases the deficiency in schooling must be overcome by additional experience necessary to have the applicant conform to the minimum acceptable by the state. It is equally important, however, where the state standards may be lower, that the applicant endeavor to achieve the level required by the rules of the NCARB in order to facilitate future reciprocal registration.

In New Jersey and many other states proof of citizenship is a prerequisite to licensing, although a declaration of intention is sufficient in others. Some thought is being given to a compromise on both of these statutory limitations which will allow short-time limited practice by foreign architects who may be invited to contribute their talents to American architecture. (*Part Two of this article will appear in August.*)



A. Reinhold Melander, President, Duluth, Minn; Chandler C. Cohagen, 1st Vice President, Billings, Mont; Paul W. Drake, 2d Vice President, Summit, NJ; A. John Brenner, Secretary, Phoenix, Ariz; C. J. Paderewski, San Diego; Earl L. Mathes, New Orleans; John E. Ramsay, Salisbury, NC; George F. Schatz, Cincinnati, Directors; Walter F. Martens, Past President, Charleston, WV

Administering the Licensing Law

John Scacchetti, AIA

This is the second of two parts.

The process of preparing for examinations entails considerable effort on the part of the office staff as well as the State Board. Applications of the candidates must be very carefully scrutinized for compliance with all requirements regarding education, experience and personal data. Cross-checking of dates will on occasion disclose errors sufficiently serious to disqualify a candidate from the examination for which he has applied. Also, on occasion, a sponsor will reply to the questionnaire in less than flattering terms, reflecting on a candidate's ability. In such cases the board is forced to evaluate the one against the others received and may ultimately be required to withhold approval until further checking is done. As there is a carry-over from previous examinations, all applicants must be checked to determine that the repeated subjects do not exceed the number permitted to be taken over, or that the prior failures do not exceed the times permitted before being required to retake the entire examination. Little time is allowed to pass after examinations before the candidates begin to display impatience over the delay in being informed of their status. It, of course, takes some time before all papers are evaluated, reviewed and grades confirmed. Lengthy sessions ensue and often extend to very late hours beyond the normal working day. Recording of grades, computing averages and preparing and mailing notices of passing or failing are part of the work to be done even before a successful candidate can be invited to appear for an oral review to test his qualifications and professional outlook on his chosen profession. The importance of the interview with the candidate becomes increasingly apparent as each succeeding session of examinations brings new prospective architects before the Board for questioning.

From the responses it is sometimes possible to ascertain weaknesses which the examination did not disclose.

In such cases the Board will emphasize the need for further study in the deficient subject and will on occasion defer the award of the license for periods up to three months to allow the candidate to review the work before the Board will consent to re-examine.

It is not expected that the new licensee will be as familiar with all aspects of the profession as one who has been in practice for many years. He is expected, however, to be reasonably familiar with all the functions of the architect if he is to be permitted to practice as a professional.

The effect is sobering; he becomes more fully aware of his professional responsibility and that it is for his benefit and for the protection of his future clients.

The Board's actions in New Jersey are directed to administration of the law, but in the conduct of this effort it has been found that a close relationship with the architectural organizations is mutually beneficial.

Public relations are improved with the Board's work and program being publicized.

Thus the State's licensees are kept informed of the Board's efforts to be of assistance to them in their work. Twice annually for the past several years the New Jersey Chapter of the AIA and the New Jersey Society of Architects have invited the candidates who have passed the written examinations to a dinner meeting, at which time the State Board reconvenes and awards certificates to the newly licensed architects. Many of them bring guests to witness their participation in the proceedings, resulting in favorable publicity for both the Board and the Societies.

Every Board is committed to the administration of the statutes as prescribed by its legislature. The personal desires of Board members are subordinated to this and cannot influence their decisions.

seems evident to m
of critical writing o
ced how stylish it
to part of the rece
development?
and drama, archite
critics of recogniza
our critics is the sam
ers. we accept t
professional critic
ot one of the creati
for more profession
usly into the matter
man urban environ
do not. A gen
t long ago with te
g some grants to st
productive scale. Th
he professional criti
aspects the pencha
having as precociou
nets describe wo
nts terrible just do
want.
oughts were express
New York Chapter
Responsibility"
blum. Some of the
of the Journal.
our critics. Qu
trouble of setting do
y and we are glad
e in the pages of
to them is to be the
ish clichés of cur
ng our efforts to so
nmental problems
btedly survive the st
because there are ar
time to achieve hor
more harm in "styl
supposed to be
analytical individ
w.

Information for people only. Not to be reprinted, copied, or otherwise used without permission of the AIA. Copyright 1962 by the American Institute of Architects, 1735 New York Ave., N.W., Washington, D.C. 20006

A common model law, when drawn and accepted by all member Boards of the National Council, will in a great many instances clarify and establish reasonably uniform requirements which should materially assist in establishing nationwide standards for licensing.

It cannot be expected however, to standardize procedures nor to overcome the need for special bylaws or requirements issued by the individual State Boards, to meet special legislative needs or to satisfy situations not normally found in other areas.

The candidate for initial or reciprocal licensing will do well to study the laws and regulations governing the practice of architecture before making application either to be examined or to practice.

There are many matters of major importance, statutory regulations notwithstanding, which should be remembered as being helpful in securing registration.

Application should be made in ample time to allow the Board to act upon it at a regularly scheduled meeting. An inquiry to the Board before filing may indicate the need for faster initial effort on the applicant's part to conform to the calendar of the Board.

Sponsors should be individuals who can be reached and who are aware of the need for immediate replies to requests for information.

Schooling and experience records should be detailed and accurate with the chronology in proper order. Experience acquired must be the sum total of a nature acceptable to the examining Board. Attempts to expand experience by counting overtime or detailing part-time employment, unless of an exceptional nature, will delay approval at best or result in rejection of the application. If the application is being made through the National Council of Architectural Registration Boards the record cannot be forwarded if more than five years have elapsed from date of initial issue or the last periodic review.

Under the new procedures recently adopted by the National Council of Architectural Registration Boards, the annual renewal will become automatic for certificate holders provided there are no unresolved counts in the record and the fees have been paid.

Where the probability of out-of-state work is indicated, it is very important that this record be kept current.

Records should be clear at all times to be sure that all infractions or violations charged have either been dismissed or the penalties satisfied, as licenses will not be issued with any counts pending. This would hold also where a penalty remains unsatisfied because the violator is beyond the jurisdiction of the Board which assessed it.

It is important to remember that documents signed before acquiring a license may constitute an illegal act and may be used by the Board as evidence in assessing a penalty for violating the law, with a delay in the issuance of a license.

Exhibits of work executed in the state where a license is being sought never fail to stir a Board to rapid action in penalizing a violator.

Laws regulating the professions are so written as to license individuals only for the purpose of establishing responsibility. Partnerships, associations with others who are not licensed as architects, or corporations seeking reciprocal registration present special problems in licensing and identification of documents.

Firms or organizations with holdover names from previous associations or continuing with the names of deceased partners are not permitted to practice in N.J. Only the active principals whose names appear in the title block and who are properly licensed are recognized as the architects in fact. The use of corporate or fictitious names on documents or reproductions is not permitted. (Exceptions are made where successors to a recently retired or deceased partner indicate the need to continue because of contract commitments, but this is permitted for a period not exceeding two years and only with the express consent of the Board.)

The Board should be consulted to determine the member or members who are required to be registered, and the manner in which the firm name must be made to appear on all documents that are issued so as to be acceptable.

If the firm or organization is composed of licensees other than architects, the professional board governing such other profession should also be consulted. Compliance with the regulations of one board does not authorize any act or transaction considered to be a violation by another Board or agency in that state.

Board-members are practicing architects who face the same problems as all other architects, but in addition devote many hours of their time in serving their state. By careful screening of the applicants they help to maintain a high level of competence and ethics among those seeking a license to practice architecture.

Information sought before applying will reduce the chances of errors or delays in the processing and will quite often forestall infraction of regulations no matter how innocent the intent may be.

Joint efforts by the boards and the National Council have developed many standards which are applicable in all states. An architect who satisfies the minimum requirements and carefully observes all rules of procedure before filing can secure a license with a minimum of effort and without unreasonable delay. ◀

March 7, 1963

Mr. John Scacchetti, FAIA
310 Monastery Place
Union City, New Jersey

Dear Mr. Scacchetti:

The American Institute of Architects desires to confer upon you the honor of Fellowship and membership in the College of Fellows in accord with the action of The Jury of Fellows at its recent meeting for your notable contribution in Service to The Institute.

The purpose of this letter is to request your presence at the 1963 Convention of The Institute to be held in Miami, Florida, starting May 6, 1963.

At a special ceremony to be held at the Annual Dinner on the evening of Thursday, May 9, at the Hotel Americana, those who have been elected to Fellowship will receive their certificates and medals. Presentation will be with appropriate ceremony and it is highly desirable that each of the newly-elected Fellows be present.

The Officers of The Institute and The Jury of Fellows join in the request that you come to receive this honor in person. Please send your response to The Octagon at an early date.

Enclosed is a Memorandum from the Department of Information Service regarding the public announcement of your advancement to Fellowship.

Yours sincerely,

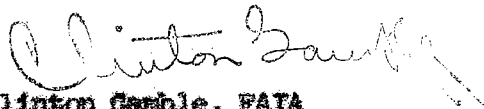

Clinton Gamble, FAIA
Secretary

Enclosure

X

Mr. Scacchetti, John

JOHN SCACCHETTI, A. I. A. - P. E. - ARCHITECT - ENGINEER
HUDSON TRUST BUILDING - 415 - 32ND STREET - UNION CITY - NEW JERSEY

TEL. UNION 5-4100

March 9, 1963

FILE COPY - PLEASE RETURN

Mr. Clinton Gamble, F.A.I.A.
Secretary
The American Institute of Architects
The Octagon
1735 New York Avenue
Washington 6, D. C.

Mr. Fellow

Dear Mr. Gamble:

With deep gratitude for the Jury's favorable action it is with great pride and pleasure that I acknowledge your notice of my advancement in the Institute to membership in the College of Fellows.

I have planned to be in Miami at the National Convention and very happy to attend the Annual Dinner on Thursday, May 9th at the Americana Hotel to participate in the ceremony.

The information regarding the public announcement will be assembled and forwarded to the Department of Information Service to conform to the schedule.

I hope that I shall be able to continue my work in behalf of architects and the profession for which past efforts I have been so richly rewarded.

Yours sincerely,
John Scacchetti
John Scacchetti, F.A.I.A.

JS/jcm
cc: P. O. Box 2465
Fort Lauderdale, Fla.

THE AMERICAN INSTITUTE OF ARCHITECTS ARCHIVES For information or study purposes only. Not to be recycled, quoted, or published without written permission from the AIA Archives, 1735 New York Ave. NW, Washington, DC 20006

MAR 13 1963

FILE COPY - PLEASE RETURN

m
Scacchetti, John

file

March 18, 1963

Mr. John Scacchetti, FAIA
310 Monastery Place
Union City, New Jersey

Dear John:

Your advancement to Fellowship in the Institute is good news indeed, and I take this opportunity to offer my congratulations.

I am looking forward to being present at the Convocation in Miami when this honor is officially bestowed upon you.

Cordially yours,

William H. Scheick, AIA

WHS:mg

ALL COPY - PLEASE RETURN

Scacchetti, John

JOHN SCACCHETTI - ARCHITECT - ENGINEER
HUDSON TRUST BUILDING - 415 - 32ND STREET - UNION CITY - NEW JERSEY

MAR 25 10 36 AM '63

TEL. UNION 5-4100

DIVISION OF
MEMBER SERVICES

March 21, 1963

M. Elliot Carroll, A. I. A.
Director, Professional Services Division
The American Institute of Architects
1735 New York Avenue N. W.
Washington 6, D. C.

Am Following

Dear Elliot:

I am looking forward to our convention in Miami for the two following reasons to wit:

- a. My induction as a Fellow in the Institute.
- b. Seeing you and following your suggestion to do a little celebrating on the occasion thereof.

Both are of prime importance and you must not fail to be present.

Meanwhile a million thanks for your sincere greetings on the momentous news.

Sincerely,

John Scacchetti

John Scacchetti
F.A.I.A.

JS/jcm

THE AMERICAN INSTITUTE OF ARCHITECTS ARCHIVES For information or study purposes only. Not to be recycled, quoted, or published without written permission from the AIA Archives, 1735 New York Ave. NW, Washington, DC 20006



THE AMERICAN INSTITUTE OF ARCHITECTS

Application for Membership Emeritus

TO BOARD OF DIRECTORS,
THE AMERICAN INSTITUTE OF ARCHITECTS:

I wish to apply for Membership Emeritus in The Institute for the following reasons:

Check the appropriate reason

- I am more than 70 years of age.
- I am 65 years of age, retired, and not engaged in the practice of architecture.
- I am unable to engage in the practice of architecture.

I have been in good standing in The Institute and the _____ chapter
for 15 successive years or more immediately preceding the date of this application.

Date JANUARY 29 1971

John Scacchetti
(APPLICANT'S FULL SIGNATURE IN INK)
FAIA

Pd. '70

79 Chapter
election (1970)

The applicant may supplement the above reasons in writing below or on sheets which he shall attach to this application. Under exceptional conditions and circumstances, The Board of Directors may lessen the period of good standing but not the requirements as checked above.

April 1971

FEB 22 1971

THE AMERICAN INSTITUTE OF ARCHITECTS ARCHIVES For information or study purposes only. Not to be recopied, quoted, or published without written permission from the AIA Archives, 1735 New York Ave. NW, Washington, DC 20006



THE AMERICAN INSTITUTE OF ARCHITECTS

RECORD AND SUMMARY OF RECOMMENDATION FOR

Membership Emeritus Election

To The Secretary and
The Committee on Membership
The American Institute of Architects

Name of Member: John Scacchetti
Corporate Membership Record:

Chapter Assignment: New Jersey Society of Architects
State Organization Assignment:

Elected: 1947
Dues Status—National: paid 1970
Dues Status — Component(s): in good standing
Age: more than 70

Recommendation: See attached record.

Suggested Effective Date: *Jan. 1*
~~March 16~~, 1971

March 16, 1971

DATE

MEMBERSHIP PROCEDURES

CERTIFICATION OF ACTION OF THE SECRETARY THE AMERICAN INSTITUTE OF ARCHITECTS

On the basis of the information provided above, and related data attached, and in accordance with the Bylaws and rules of The Institute, as the Chairman of the Committee on Membership and the Secretary of The American Institute of Architects, I hereby declare that I have this day elected John Scacchetti, FAIA, a Member Emeritus.

Effective: *Jan. 1*
~~March 16~~, 1971

March 16, 1971

DATE

[Signature]
SECRETARY

~~John~~ John Seacchetti
AIA

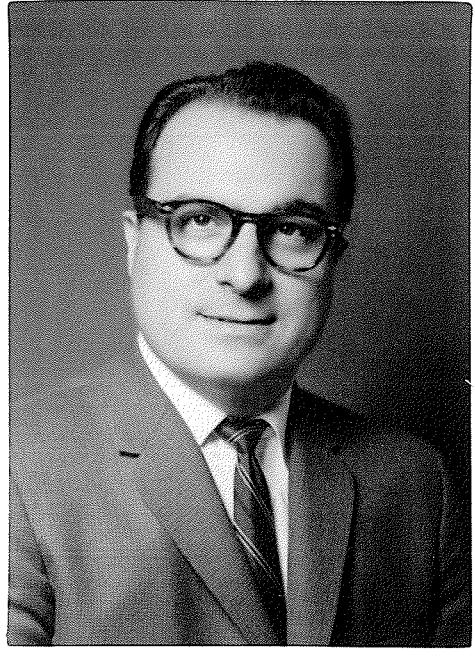

John Seacchetti
FLA



FLOP!!

332



JOHN SCACCHETTI, A. I. A. - P. E. - ARCHITECT - ENGINEER

HUDSON TRUST BUILDING - 415 - 32ND STREET - UNION CITY - NEW JERSEY

TEL. UNION 5-4100

March 11, 1963

John Scacchetti, F.A.I.A., born New York City 1900, Resident New Jersey since 1902.

Education Elementary and High Schools, Mechanics Institute 1915-1919, Extension Evening Courses, College City of New York 1921-1923, Columbia University 1923-24, 1927-1928.

Early training in New York offices of Schwartz & Gross and Sugarman & Berger included boom years after World War I with most of the activity directed toward apartment house and residential APT Hotel design. Following this, midtown Manhattan developed rapidly as a light industrial area with intense architectural activity on this type of building. Later association, in charge of the office of William Laurence Bottomley and Bottomley, Wagner & White featured work on large private residences, high rise office buildings, Hospitals and larger cooperative apartment buildings, one of which was the internationally known River House, the first tower apartment building constructed under the then new Housing Law, for which the office received several awards.

As an associate of Kelly & Gruzen important work on military installations and war housing was done during World War 2.

Resuming private practice in 1946, a large proportion of the work resulting was produced in the rapidly developing industrial areas of Northern New Jersey with many new plants, trucking terminals, sales and office buildings, many of which were owned or occupied by nationally known companies.

First license obtained in New Jersey in 1927, additional registration was secured in New York in 1936 and later certified through the National Council of Architectural Registration Boards in 1946.

Became an associate member in New York Chapter A.I.A. in 1938, Corporate Member in New Jersey Chapter in 1947 and also became a member of the New Jersey Society of Architects the same year.

Served as Chairman of committees including Program, Public Relations, Legislative, State Convention, A.I.A., Producers Council, Budget and Finance and many others. Director in both Society and Chapter 1951 to 1957.

From 1957 to 1961 served as secretary, 2nd Vice Pres., 1st Vice Pres., and President of both the New Jersey Chapter and the New Jersey Society.

JOHN SCACCHETTI, A. I. A. - P. E. - ARCHITECT - ENGINEER
HUDSON TRUST BUILDING - 415 - 32ND STREET - UNION CITY - NEW JERSEY

TEL. UNION 5-4100

-2-

Was appointed to the State Board of Architects by the Governor in 1957 and on expiration of term as President of the Board, was requested by the then Governor Meyner and Attorney General Furman to accept another 5 year term expiring in 1966.

Appointed in 1958 to serve on special Statutory Board, composed of Architects and Engineers to resolve problems arising in both professions.

Appointed 1958 and Chairman since 1959 to date of National Licensing Committee for the N.C.A.R.B. with the development of a national registration act as one objective.

Appointed Co-Chairman of A.I.A.-N.C.A.R.B. Liason Committee 1962-63.

Articles have been contributed to professional publications including Administration of Licensing Laws which appeared in the June and August 1962 issues of the A.I.A. Journal.

Reside with wife in Union City, 2 sons, both married and 2 grandchildren.

Scacchetti, J

N. J. Building Contractor
v. 26, no. 5, May 1963
pp 11, 24

John Scacchetti Named Fellow of AIA

Architect John Scacchetti, of Union City, has been named a Fellow of The American Institute of Architects for "distinguished service to the Institute" and public service.

The announcement was made last month by Howard L. McMurray, A.I.A., President of The New Jersey Society of Architects and the New Jersey Chapter of The American Institute of Architects, whose Executive Committee had proposed Mr. Scacchetti for the coveted professional honor.

The Fellowship was formally conferred upon Mr. Scacchetti on May 9th, during the National Convention of the American Institute of Architects in Miami Beach, where he received a certificate and medal emblematic of the honor.

The Fellowship award comes to John Scacchetti in his 35th year of practice. Born in New York City, he attended City College and Columbia University and obtained his license to practice architecture in New York and New Jersey in 1927. He holds a certificate of the National Council of Architectural Registration Boards.

Mr. Scacchetti is perhaps best known for his design of the internationally-known River House in the fashionable east side of New York City, the first tower apartment building constructed under the then new Housing Law of 1929. His private practice includes design of a large number of plants, trucking terminals, sales and office buildings in the northern New Jersey area.

John Scacchetti has long been active in architectural circles. He is a Past President of The New Jersey Society of Architects, a Past President of The New Jersey Chapter of The American Institute of Architects, a Past President of The New Jersey State Board of Architects. At the special request of former Governor Meyner and Attorney General

Scacchetti

(Continued from page 11)

Furman, in 1961, he accepted appointment to a second five-year term on the New Jersey State Board of Architects because of his outstanding work on licensing matters.

In 1953 he founded the Hudson County Chapter of the New Jersey Society of Architects. As President of the New Jersey Society of Architects, in 1960-61, he broadened contacts and liaison with other professional and state organizations in the construction and allied fields, thereby greatly contributing to the stature and enhancement of the architectural profession.

As Chairman of the Licensing Committee of the National Council of Architectural Registration Boards, he has assisted in drafting licensing laws for several states, and is currently drafting a model National Licensing Law.

He and Mrs. Scacchetti live on Monastery Place, in Union City. They have two married sons and two grand children.

THE AMERICAN INSTITUTE OF ARCHITECTS ARCHIVES For information or study purposes only. Not to be recycled, quoted, or published without written permission from the AIA Archives, 1735 New York Ave. NW, Washington, DC 20006



THE ARCHITECTS LEAGUE OF NORTHERN NEW JERSEY

A SECTION OF THE NEW JERSEY SOCIETY OF ARCHITECTS — AIA



ROBERT F. GEBHARDT, AIA	President
O. DANIEL WINTER, AIA	1st Vice President
	President Designate
ROSS R. MAMOLA, AIA	2nd Vice President
MARIO SERGIO, AIA	2nd Vice President
FRANK ADLER, AIA	Treasurer
ROMEO AYBAR, AIA	Secretary

May 3, 1971

Miss Maureen Marx, Director
 Membership Procedures
 The American Institute of Architects
 The Octagon
 1735 New York Avenue, N.W.
 Washington, D.C. 20006

Dear Miss Marx:

Enclosed please find information you requested for the Institute's Baldwin Memorial Archive records for John Scacchetti.

Very truly yours,

Robert F. Gebhardt, R.A., A.I.A.
 President
 ARCHITECTS LEAGUE OF NORTHERN N.J.

J. THOMAS CAMLET, AIA — '71
 CHARLES A. WOOD, AIA — '71
 BERNARD HERSH, AIA — '71

DICRAN LEVON GEDICKIAN, AIA — '72
 JOHN NAKROSIS, AIA — '72
 SAM ZYWOTOW, AIA — '72

JOSEPH CECCO, AIA — '73
 VINCENT S. D'AMORE, AIA — '73
 HUGH ROMNEY, AIA — '73

BOARD OF DIRECTORS

John

BALDWIN MEMORIAL ARCHIVE
of American Architects

NO. _____

Name: Scacchetti, John of (address) Union City, N.J.

Born: 1900 at New York, N.Y. Died: March 22, 1971 at Union City, N.J.

Parents: _____ and _____

Married: Yes _____ of _____ on _____

Children: two sons

Education: City College of N.Y. and Columbia University

Training; and practice as Principal: (Firm Names, Places, Dates, Specialization)

Practice New York City 1926 to 1943
1943 Own office in Union City, N.J.

Professional Memberships and Service: (Institute and Chapter Activities; Teaching)

President N.J. Society of Architects 1960-61
Fellow A.I.A.

Other Affiliations: (Religious, Fraternal, Political, Social)

Public Service: (Civil and Military; Community, State, National)

Published Material: (Articles and Addresses; Executed Work; Biographical Data)

THE AMERICAN INSTITUTE OF ARCHITECTS ARCHIVES For information or study purposes only. Not to be recopied, quoted, or published without written permission from the AIA Archives, 1735 New York Ave. NW, Washington, DC 20006

(OVER)

General Background: (Personal Characteristics and Accomplishments; Interests, Digressions, Travels, Friendships, Side-lights, Honors, and Awards.)

President N.J. Board of Architects 1957
Reappointed Member of Board 1961

Named Architect of the Year for New Jersey 1964

Practice included:

Public buildings, schools, post offices, office buildings,
industrial and restoration of historic buildings.

Principal Commissions: (Classified, with locations and Reference Data) (Above)

Compiled by: Robert F. Gebhardt, A.I.A.

Date: May 4, 1971

Acknowledgements: